



NORTH BRANCH

—Minnesota—

Kevin Schieber
Mayor

Robert Canada
Councilmember/Acting Mayor

Jeff Goulet
Councilmember

Jim Ibinger
Councilmember

Patrick Meacham
Councilmember

**CITY COUNCIL
REGULAR AGENDA
WEDNESDAY, FEBRUARY 11, 2026 @ 6:00 PM
CITY HALL, 6408 ELM STREET, NORTH
BRANCH, MN 55056**

1. CALL TO ORDER
2. PLEDGE OF ALLEGIANCE
3. ROLL CALL
4. AGENDA APPROVAL
 - a. Approve Agenda ACTION
5. PRESENTATION & PROCLAMATION
6. PUBLIC COMMENT

Provides an opportunity for the public to address the Council on items that are not on the Agenda. Please raise your hand to be recognized. Please state your name and address for the record. This section is for the express purpose of addressing concerns of City services and operations. It shall not be used to clarify individual's views for political purposes.
7. CONSENT AGENDA

All matters listed under Consent Agenda are considered routine and/or non-controversial and will be approved by one motion. There will be no separate discussion of these items unless a Councilmember or citizen so requests, in which case the item will be removed from the Consent Agenda and considered in its normal sequence on the Agenda.

 - a. Claims ACTION
 - b. Approval of Minutes - Regular Council Meeting - January 27, 2026, 7:00 PM ACTION
 - c. Approve Gambling LG220 Exempt Permit - NWTF Long Spurs of Sunrise River ACTION
 - d. Approval of Resolution R-287-2026 Authorizing Payment For Pay Request #8 for CoRd 30 Street Improvement Project ACTION
 - e. Approval of the Financing Agreement with KS State Bank for the Purchase and Upfitting of Four Squad Cars ACTION

- f. Approval of Resolution R-286-2026 Accepting 2025 Donations to the City of North Branch ACTION
 - g. Approval of Resolution R-289-2026 to apply for a DNR Local Trail Connections grant for Flink Ave Phase II Trail ACTION
 - h. Approval of Resolution R-290-2026 to submit a capital funding request for the Circle of Honor Regional Veterans Memorial ACTION
 - i. Approval of Resolution R-288-2026 to authorize the Sale of Equipment Bonds ACTION
 - j. Approval to utilize interfund loans for purchase of equipment ACTION
 - k. Receive Legal Report from City Attorney's office INFO
8. PUBLIC HEARINGS
9. STAFF REPORTS
- a. Consider approval of Ordinance 407-26 allowing the procurement of charitable gambling proceeds for park and trail additions and maintenance funding. ACTION
10. MAYOR/CITY COUNCIL
11. ADJOURNMENT

Since we do not have time to discuss every point presented, it may seem that decisions are preconceived. However, background information is provided to the City Council on each Agenda item in advance from Staff and appointed Commissions; and decisions are based on this information and past experiences. In addition some items may also have been discussed preliminarily at Council Work Sessions. If you are aware of information that has not been discussed, please raise your hand to be recognized. Comments that are pertinent are appreciated. Items requiring excessive time may be continued to another meeting.



Prepared By:

Presenter:

Date: 01/06/2026

Board & Commission: City Council

Subject: Claims

Claims Summary

Voting Requirements:

Voting Options Simple Majority

City of North Branch

ACH Checks

6056 to 6070- \$432,893.48

Checks

92918 to 92993 - \$271,213.76

Payroll

01/30/2026 - \$138,982.42

Accounts Payable

Computer Check Proof List by Vendor

User: SharonWright
 Printed: 02/05/2026 - 11:50AM
 Batch: 00002.02.2026 - 02052026



Invoice No	Description	Amount	Pmt Date	Acct Number	Reference
Vendor: 1005	ACE SOLID WASTE			Check Sequence: 1	ACH Enabled: False
12863596T067	FEBRUARY 2026 REFUSE	63.36	02/05/2026	615-49550-50387	
12863596T067	FEBRUARY 2026 REFUSE	139.63	02/05/2026	101-42280-50387	
12863596T067	FEBRUARY 2026 REFUSE	261.52	02/05/2026	602-49450-50387	
12863596T067	FEBRUARY 2026 REFUSE	244.22	02/05/2026	101-41940-50387	
12863596T067	FEBRUARY 2026 REFUSE	111.22	02/05/2026	101-45500-50387	
12863596T067	FEBRUARY 2026 REFUSE	155.25	02/05/2026	609-49750-50387	
12863596T067	FEBRUARY 2026 REFUSE	128.79	02/05/2026	615-49550-50387	
12863596T067	FEBRUARY 2026 REFUSE	335.64	02/05/2026	101-43000-50387	
	Check Total:	1,439.63			
Vendor: 1662	AMAZON CAPITAL SERVICES			Check Sequence: 2	ACH Enabled: False
13CL-4VWF-P4P3	PW BLDG MAINT	487.98	02/05/2026	101-43000-50401	
14M3-QYRP-GD4V	PD OPERATING SUPPLIES	92.98	02/05/2026	101-42110-50210	
161R-1XRH-CM17	SPEAKER BAR/CAM	80.10	02/05/2026	101-41420-50201	
1V39-XTRW-9TMG	OFFICE SUPPLIES	26.59	02/05/2026	101-42110-50210	
1WC9-LWWL-JPTW	OPERATING SUPPLIES	45.52	02/05/2026	101-42110-50210	
	Check Total:	733.17			
Vendor: 1036	AT & T MOBILITY			Check Sequence: 3	ACH Enabled: False
287294264933X02	PUBLIC SAFETY MOBILES	2,105.50	02/05/2026	101-41420-50321	
	Check Total:	2,105.50			
Vendor: 1049	BELLBOY CORPORATION			Check Sequence: 4	ACH Enabled: False
0110766400	LIQUOR	265.21	02/05/2026	609-48000-50251	
0210279100	LIQUOR	2,306.35	02/05/2026	609-49750-50251	

Invoice No	Description	Amount	Pmt Date	Acct Number	Reference
0210279100	WINE	95.65	02/05/2026	609-49750-50253	
0210279400	LIQUOR	1,181.15	02/05/2026	609-48000-50251	
0300644400	THC	429.90	02/05/2026	609-48000-50254	
	Check Total:	4,278.26			
Vendor: 1052	BERNICKS			Check Sequence: 5	ACH Enabled: False
10450128	BEER	1,653.00	02/05/2026	609-48000-50252	
10450133	BEER	1,843.65	02/05/2026	609-49750-50252	
10450134	N/A SALES	79.37	02/05/2026	609-49750-50250	
10450135	BEER CREDIT	-83.78	02/05/2026	609-49750-50252	
10452290	BEER	1,130.50	02/05/2026	609-48000-50252	
10452292	BEER	5,140.60	02/05/2026	609-49750-50252	
10452293	N/A SALES	19.20	02/05/2026	609-49750-50250	
	Check Total:	9,782.54			
Vendor: 1066	BREAKTHRU BEVERAGE MN WINE & SPIRITS, LLC			Check Sequence: 6	ACH Enabled: False
125309634	LIQUOR	1,346.02	02/05/2026	609-49750-50251	
125404905	LIQUOR	75.00	02/05/2026	609-48000-50251	
125406785	LIQUOR	1,523.84	02/05/2026	609-48000-50251	
125406786	WINE	129.65	02/05/2026	609-48000-50253	
125407036	WINE	331.30	02/05/2026	609-49750-50253	
125407486	LIQUOR	2,016.75	02/05/2026	609-49750-50251	
414404217	LIQUOR CREDIT	-45.46	02/05/2026	609-49750-50251	
414438477	LIQUOR CREDIT	-181.97	02/05/2026	609-49750-50251	
414443799	LIQUOR CREDIT	-61.76	02/05/2026	609-49750-50251	
	Check Total:	5,133.37			
Vendor: 1082	Capitol Beverage Sales LP			Check Sequence: 7	ACH Enabled: False
3240551	N/A	91.00	02/05/2026	609-49750-50250	
3240551	BEER	843.40	02/05/2026	609-49750-50252	
3240552	BEER	405.10	02/05/2026	609-48000-50252	
3240552	N/A	65.05	02/05/2026	609-48000-50250	
	Check Total:	1,404.55			

Invoice No	Description	Amount	Pmt Date	Acct Number	Reference
Vendor: 2315 437408	CENTRAL-MCGOWAN, INC CYLINDER RENTALS	60.25	02/05/2026	Check Sequence: 8 101-43000-50210	ACH Enabled: False
	Check Total:	60.25			
Vendor: 1098 11.00429.13 11.00429.14	CHISAGO COUNTY AUDITOR-TREASURER 2025 PROPERTY TAXES 2025 PROPERTY TAXES	122.92 13.84	02/05/2026 02/05/2026	Check Sequence: 9 612-49700-50455 612-49700-50455	ACH Enabled: False
	Check Total:	136.76			
Vendor: 1109 4257040939 4257041045 4257041045 4257041045 4257041045 4257041045 4257041045 4257041045 4257041045 4257041045 4257041045 4257041045 4257041045 4257055439 4257055509	CINTAS UNIFORMS PW UNIFORMS PW UNIFORMS PW UNIFORMS PW UNIFORMS PW UNIFORMS PW UNIFORMS PW UNIFORMS PW UNIFORMS PW UNIFORMS PW UNIFORMS PW UNIFORMS PW UNIFORMS PW UNIFORMS PW SHOP SUPPLIES OPERATING SUPPLIES OPERATING SUPPLIES	30.53 2.57 0.40 11.09 2.77 0.40 1.34 9.19 4.35 25.27 76.68 10.55 49.36 48.49	02/05/2026 02/05/2026 02/05/2026 02/05/2026 02/05/2026 02/05/2026 02/05/2026 02/05/2026 02/05/2026 02/05/2026 02/05/2026 02/05/2026 02/05/2026 02/05/2026 02/05/2026 02/05/2026 02/05/2026	Check Sequence: 10 602-49450-50237 620-49600-50237 101-45000-50237 602-49450-50237 101-45500-50237 609-49750-50237 101-42110-50237 612-49700-50237 101-41940-50237 615-49550-50237 101-43000-50237 101-43000-50300 609-49750-50300 609-48000-50300	ACH Enabled: False
	Check Total:	272.99			
Vendor: 1902 362145	CIVICPLUS LLC CODIFICATION SOFTWARE	1,323.00	02/05/2026	Check Sequence: 11 101-41420-50242	ACH Enabled: False
	Check Total:	1,323.00			
Vendor: 1114 277888	Coffee Mill Inc PD COFFEE	154.00	02/05/2026	Check Sequence: 12 101-42110-50210	ACH Enabled: False
	Check Total:	154.00			

Invoice No	Description	Amount	Pmt Date	Acct Number	Reference
Vendor: 1122	Crystal Springs Ice			Check Sequence: 13	ACH Enabled: False
02-603479	N/A SALES	89.88	02/05/2026	609-48000-50250	
02-603480	N/A SALES	158.88	02/05/2026	609-49750-50250	
	Check Total:	248.76			
Vendor: 1129	DAHLHEIMER DISTRIBUTING			Check Sequence: 14	ACH Enabled: False
2678397	N/A SALES	71.88	02/05/2026	609-49750-50250	
2678398	THC	495.50	02/05/2026	609-49750-50254	
2678399	LIQUOR	287.60	02/05/2026	609-49750-50251	
2678400	BEER	6,814.45	02/05/2026	609-49750-50252	
2678543	BEER	1,545.45	02/05/2026	609-48000-50252	
2678823	THC	150.00	02/05/2026	609-48000-50254	
2678824	LIQUOR	207.60	02/05/2026	609-48000-50251	
2684295	N/A SALES	190.60	02/05/2026	609-49750-50250	
2684321	N/A SALES	18.50	02/05/2026	609-48000-50250	
2684330	THC	258.50	02/05/2026	609-48000-50254	
2684331	LIQUOR	416.60	02/05/2026	609-48000-50251	
2684332	BEER	2,199.45	02/05/2026	609-48000-50252	
2684333	THC	565.00	02/05/2026	609-49750-50254	
2684334	BEER	5,991.40	02/05/2026	609-49750-50252	
2684726	BEER CREDIT	-210.57	02/05/2026	609-49750-50252	
2684730	THC CREDIT	-16.50	02/05/2026	609-49750-50254	
	Check Total:	18,985.46			
Vendor: 2132	Data-Smart Computers, Inc.			Check Sequence: 15	ACH Enabled: False
95296	Data Smart Labor	1,268.75	02/05/2026	101-41420-50300	
96991	FIREWALL UPDATES - NEPTUNE	290.00	02/05/2026	101-41420-50300	
	Check Total:	1,558.75			
Vendor: 1133	Dell Marketing, L.P.			Check Sequence: 16	ACH Enabled: False
10857794064	10 NEW LAPTOPS - CITY	12,809.24	02/05/2026	101-41420-50207	
10857998304	PD LAPTOP	1,832.38	02/05/2026	701-70100-50550	
10859034488	PD LAPTOP	3,194.32	02/05/2026	101-41420-50207	

Invoice No	Description	Amount	Pmt Date	Acct Number	Reference
	Check Total:	17,835.94			
Vendor: 1152	EHLERS			Check Sequence: 17	ACH Enabled: False
100651	GENERAL TIF SERVICES	225.00	02/05/2026	393-47000-50306	
104810	DBS Sr Proforma Review	372.50	02/05/2026	201-46500-50300	
104811	Project Heart - Review	811.25	02/05/2026	201-46500-50300	
104812	General TIF DBS Housing	300.00	02/05/2026	201-46500-50300	
	Check Total:	1,708.75			
Vendor: 1179	Fastenal Company			Check Sequence: 18	ACH Enabled: False
MNTC3242325	SHOP SUPPLIES	267.30	02/05/2026	101-43000-50210	
	Check Total:	267.30			
Vendor: 1706	Flaherty & Hood, P.A.			Check Sequence: 19	ACH Enabled: False
DEC 2025	LABOR & EMP MATTERS	2,090.00	02/05/2026	101-41610-50304	
	Check Total:	2,090.00			
Vendor: 1192	Flying Star Products			Check Sequence: 20	ACH Enabled: False
26001	SHOP SUPPLIES	164.18	02/05/2026	101-43000-50210	
26001	SHOP SUPPLIES	164.17	02/05/2026	602-49450-50210	
	Check Total:	328.35			
Vendor: 1225	Graybar			Check Sequence: 21	ACH Enabled: False
9351560314	CITY HALL PARKING LOT LIGHTS	3,140.60	02/05/2026	101-41940-50401	
	Check Total:	3,140.60			
Vendor: 1749	GRJ PRO/MOTE Inc.			Check Sequence: 22	ACH Enabled: False
852697	ADVERTISING	105.00	02/05/2026	609-49750-50340	
852697	ADVERTISING	45.00	02/05/2026	609-48000-50340	
	Check Total:	150.00			
Vendor: 1265	Isanti-Chisago County Star			Check Sequence: 23	ACH Enabled: False
25928	PUBLIC NOTICES	6.28	02/05/2026	101-41910-50351	

Invoice No	Description	Amount	Pmt Date	Acct Number	Reference
	Check Total:	6.28			
Vendor: 1269	IUOE Local 49 Fringe Benefit			Check Sequence: 24	ACH Enabled: False
FEB 2026	PW HEALTH	21,910.00	01/16/2026	101-00000-21706	
FEB 2026	CITY HEALTH	54,932.00	01/16/2026	101-00000-21706	
	Check Total:	76,842.00			
Vendor: 1650	John Hirsch's Cambridge Motors			Check Sequence: 25	ACH Enabled: False
CHCS428223	PD SQUAD REPAIRS	982.71	02/05/2026	101-42110-50404	
CHCS428836	PD SQUAD REPAIRS	2,653.56	02/05/2026	101-42110-50404	
	Check Total:	3,636.27			
Vendor: 1279	JOHNSON BROTHERS LIQUOR CO			Check Sequence: 26	ACH Enabled: False
166687	LIQUOR CREDIT	-695.04	02/05/2026	609-49750-50251	
2975070	WINE	0.31	02/05/2026	609-49750-50253	
2975071	N/A SALES	145.84	02/05/2026	609-49750-50250	
2975072	LIQUOR	51.49	02/05/2026	609-49750-50251	
2975073	WINE	447.18	02/05/2026	609-49750-50253	
2975074	LIQUOR	2,549.56	02/05/2026	609-49750-50251	
2975075	LIQUOR	1,985.08	02/05/2026	609-49750-50251	
2975076	WINE	551.44	02/05/2026	609-49750-50253	
2975077	LIQUOR	2,433.08	02/05/2026	609-49750-50251	
2975078	THC	116.60	02/05/2026	609-48000-50254	
2975079	LIQUOR	293.68	02/05/2026	609-48000-50251	
2975080	WINE	299.04	02/05/2026	609-48000-50253	
2975081	WINE	664.39	02/05/2026	609-48000-50253	
2975082	LIQUOR	394.32	02/05/2026	609-48000-50251	
2975083	LIQUOR	1,265.10	02/05/2026	609-48000-50251	
2975084	LIQUOR	3,884.43	02/05/2026	609-48000-50251	
2980158	LIQUOR	102.68	02/05/2026	609-49750-50251	
2980159	WINE	1,819.20	02/05/2026	609-49750-50253	
2980160	LIQUOR	617.37	02/05/2026	609-49750-50251	
2980161	WINE	93.78	02/05/2026	609-49750-50253	
2980162	N/A SALES	38.84	02/05/2026	609-49750-50250	

Invoice No	Description	Amount	Pmt Date	Acct Number	Reference
2980163	WINE	483.04	02/05/2026	609-48000-50253	
2980164	LIQUOR	607.13	02/05/2026	609-48000-50251	
2980165	WINE	93.78	02/05/2026	609-48000-50253	
2980166	N/A SALES	38.84	02/05/2026	609-48000-50250	
2980167	LIQUOR	759.36	02/05/2026	609-48000-50251	
2980530	WINE	495.50	02/05/2026	609-49750-50253	
2980531	WINE	207.50	02/05/2026	609-48000-50253	
	Check Total:	19,743.52			
Vendor: 1320	Lynette Koalska			Check Sequence: 27	ACH Enabled: False
253501	SOFTWARE	456.75	02/05/2026	101-41420-50242	
	Check Total:	456.75			
Vendor: 1643	McDonald Distributing			Check Sequence: 28	ACH Enabled: False
844551	BEER	2,075.30	02/05/2026	609-48000-50252	
844551	THC	80.00	02/05/2026	609-48000-50254	
844644	LIQUOR	213.20	02/05/2026	609-49750-50251	
844645	BEER	3,603.20	02/05/2026	609-49750-50252	
844645	LIQUOR	33.60	02/05/2026	609-49750-50251	
844655	LIQUOR CREDIT	-114.26	02/05/2026	609-49750-50251	
844714	BEER CREDIT	-199.26	02/05/2026	609-49750-50252	
844746	BEER CREDIT	-43.28	02/05/2026	609-48000-50252	
845623	LIQUOR CREDIT	-30.87	02/05/2026	609-49750-50251	
845627	THC	71.76	02/05/2026	609-49750-50254	
845627	BEER	6,171.65	02/05/2026	609-49750-50252	
845661	LIQUOR	180.90	02/05/2026	609-48000-50251	
845661	BEER	5,814.40	02/05/2026	609-48000-50252	
845741	LIQUOR	227.20	02/05/2026	609-49750-50251	
845885	LIQUOR	30.87	02/05/2026	609-49750-50251	
845886	LIQUOR CREDIT	-46.30	02/05/2026	609-49750-50251	
845990	BEER CREDIT	-341.40	02/05/2026	609-49750-50252	
845991	BEER CREDIT	-546.00	02/05/2026	609-48000-50252	
	Check Total:	17,180.71			

Invoice No	Description	Amount	Pmt Date	Acct Number	Reference
Vendor: 1348 3002878	Metro Sales Inc. COPY MACHINE LEASE	259.00	02/05/2026	Check Sequence: 29 101-41420-50219	ACH Enabled: False
	Check Total:	259.00			
Vendor: 1353 16640100115202	MIDCONTINENT INTERNET	1,081.95	02/05/2026	Check Sequence: 30 101-41420-50243	ACH Enabled: False
	Check Total:	1,081.95			
Vendor: 1364 1169756	Minnesota Elevator, Inc. FEBRUARY MONTHLY SERVICE	140.00	02/05/2026	Check Sequence: 31 101-41940-50300	ACH Enabled: False
	Check Total:	140.00			
Vendor: 1376 67599 68368 68368	MMUA 2026 DRUG/ALCOHOL TESTING PRE-EMPLOYMENT TESTING PRE-EMPLOYMENT TESTING	700.00 50.00 50.00	02/05/2026 02/05/2026 02/05/2026	Check Sequence: 32 101-43000-50314 101-42110-50314 101-43000-50314	ACH Enabled: False
	Check Total:	800.00			
Vendor: 1388 1984-3295	MN Dept Of Natural Resources ANNUAL PERMIT	3,397.37	02/05/2026	Check Sequence: 33 615-49550-50236	ACH Enabled: False
	Check Total:	3,397.37			
Vendor: 1404 FEB 2026	MN TEAMSTERS #320 FEB DUES	29.00	02/05/2026	Check Sequence: 34 101-00000-21708	ACH Enabled: False
	Check Total:	29.00			
Vendor: 1341 48513	Mobile Health Services ANNUAL HEARING TEST	825.00	02/05/2026	Check Sequence: 35 101-43000-50314	ACH Enabled: False
	Check Total:	825.00			
Vendor: 2203 17558 17779 17884	Morris Electronics, Inc. APPS FOR ENTERPRISE ON SITE SUPPORT PD IT SUPPORT	95.84 1,592.00 62.50	02/05/2026 02/05/2026 02/05/2026	Check Sequence: 36 101-41420-50300 101-41420-50300 101-41420-50300	ACH Enabled: False

Invoice No	Description	Amount	Pmt Date	Acct Number	Reference
17916	M365 APPS FOR ENTERPRISE	95.84	02/05/2026	101-41420-50300	
	Check Total:	1,846.18			
Vendor: 1423	N.B. Area Public Schools-Fuel			Check Sequence: 37	ACH Enabled: False
2026-049	MOTOR FUELS	167.44	02/05/2026	602-49450-50212	
2026-049	MOTOR FUELS	2,585.53	02/05/2026	101-42110-50212	
2026-049	MOTOR FUELS	660.26	02/05/2026	101-43000-50212	
2026-049	MOTOR FUELS	186.60	02/05/2026	615-49550-50212	
2026-049	MOTOR FUELS	66.32	02/05/2026	620-49600-50212	
2026-049	MOTOR FUELS	53.43	02/05/2026	101-42400-50212	
2026-049	MOTOR FUELS	413.22	02/05/2026	101-42280-50212	
	Check Total:	4,132.80			
Vendor: 1449	Nuss Truck & Equipment			Check Sequence: 38	ACH Enabled: False
PS0270220-1	FUEL FILLER CAP	51.38	02/05/2026	101-43000-50404	
	Check Total:	51.38			
Vendor: 1474	PHILLIPS WINE & SPIRITS, INC			Check Sequence: 39	ACH Enabled: False
5115226	LIQUOR	1,802.14	02/05/2026	609-49750-50251	
5115227	LIQUOR	1,290.00	02/05/2026	609-49750-50251	
5115227	WINE	551.92	02/05/2026	609-49750-50253	
5115228	THC	168.00	02/05/2026	609-49750-50254	
5115229	LIQUOR	1,273.03	02/05/2026	609-48000-50251	
5115230	WINE	637.76	02/05/2026	609-48000-50253	
5118986	LIQUOR	2,663.26	02/05/2026	609-49750-50251	
5118987	N/A SALES	91.68	02/05/2026	609-49750-50250	
5118988	LIQUOR	2,716.86	02/05/2026	609-48000-50251	
5118989	N/A SALES	179.68	02/05/2026	609-48000-50250	
570230	WINE CREDIT	-85.84	02/05/2026	609-49750-50253	
	Check Total:	11,288.49			
Vendor: 1884	SUSO 4 North Branch, LP Pine Tree Commercial Realty			Check Sequence: 40	ACH Enabled: False
FEB2026	STORE 2 RENT FEBRUARY	6,574.33	02/05/2026	609-48000-50412	

Invoice No	Description	Amount	Pmt Date	Acct Number	Reference
	Check Total:	6,574.33			
Vendor: 1482 144886	Post Haste Business Solutions OFFICE SUPPLIES	254.97	02/05/2026	Check Sequence: 41 101-41940-50210	ACH Enabled: False
	Check Total:	254.97			
Vendor: 1484 855536-01-26	Premium Waters Inc. OPERATING SUPPLIES	40.66	02/05/2026	Check Sequence: 42 609-49750-50210	ACH Enabled: False
	Check Total:	40.66			
Vendor: 2232 W-114846	Pryes Brewing Company LLC BEER	133.00	02/05/2026	Check Sequence: 43 609-49750-50252	ACH Enabled: False
	Check Total:	133.00			
Vendor: 2019 Q2196655 Q2196655 Q2196655 Q4 STUFFER Q4 STUFFER Q4 STUFFER	QUADIANT, INC UB STUFFER UB STUFFER UB STUFFER UB BILL STUFFER UB BILL STUFFER UB BILL STUFFER	137.99 137.99 137.99 137.99 137.99 137.99	02/05/2026 02/05/2026 02/05/2026 02/05/2026 02/05/2026 02/05/2026	Check Sequence: 44 602-49450-50210 612-49700-50210 615-49550-50210 615-49550-50210 602-49450-50210 612-49700-50210	ACH Enabled: False
	Check Total:	827.94			
Vendor: 2066 B021134 B021193	RMB Environmental Laboratories, Inc. WASTEWATER TESTING WATER TESTING	130.20 105.00	02/05/2026 02/05/2026	Check Sequence: 45 602-49450-50315 615-49550-50315	ACH Enabled: False
	Check Total:	235.20			
Vendor: 2257 25 26	Row Sewer Service PORTABLE BATHROOM RENTALS PORTABLE BATHROOM RENTALS	390.00 540.00	02/05/2026 02/05/2026	Check Sequence: 46 101-45000-50415 101-45000-50415	ACH Enabled: False
	Check Total:	930.00			
Vendor: 1534	SOUTHERN GLAZERS WINE & SPIRITS OF MINNESOTA			Check Sequence: 47	ACH Enabled: False

Invoice No	Description	Amount	Pmt Date	Acct Number	Reference
2716796	LIQUOR	2,511.43	02/05/2026	609-48000-50251	
2717437	LIQUOR	6,946.86	02/05/2026	609-49750-50251	
2718916	LIQUOR	3,308.49	02/05/2026	609-48000-50251	
2718916	WINE	452.76	02/05/2026	609-48000-50253	
2719362	LIQUOR	6,099.96	02/05/2026	609-49750-50251	
2719363	WINE	449.04	02/05/2026	609-49750-50253	
	Check Total:	19,768.54			
Vendor: 1550	STREICHERS			Check Sequence: 48	ACH Enabled: False
1805651	PD UNIFORMS	414.98	02/05/2026	101-42110-50237	
1806882	PD UNIFORMS	59.99	02/05/2026	101-42110-50237	
	Check Total:	474.97			
Vendor: 2321	Target Solutions Learning, LLC			Check Sequence: 49	ACH Enabled: False
135868	HR LEARNING MGMT SYSTEM	6,950.90	02/05/2026	101-41420-50242	
	Check Total:	6,950.90			
Vendor: 1583	U.S. Bank-CM9690			Check Sequence: 50	ACH Enabled: False
8051212	EDA TXVLE REF LEASE REV BOND 2017	2,875.00	02/05/2026	387-47000-50620	
	Check Total:	2,875.00			
Vendor: 1598	Viking Coca-Cola Bottling Co.			Check Sequence: 51	ACH Enabled: False
3849313	N/A SALES	414.00	02/05/2026	609-49750-50250	
	Check Total:	414.00			
Vendor: 1611	WATSON COMPANY			Check Sequence: 52	ACH Enabled: False
155488	N/A SALES	1,249.98	02/05/2026	609-49750-50250	
155488	OPERATIONS SUPPLIES	77.54	02/05/2026	609-49750-50210	
	Check Total:	1,327.52			
Vendor: 1729	Windstream Services			Check Sequence: 53	ACH Enabled: False
11734875 JAN	LANDLINES/FAXES	319.82	02/05/2026	101-41420-50321	
	Check Total:	319.82			

Invoice No	Description	Amount	Pmt Date	Acct Number	Reference
	Total for Check Run:	255,981.48			
	Total of Number of Checks:	53			

Accounts Payable

Computer Check Proof List by Vendor

User: TiffaniFolstad
 Printed: 02/02/2026 - 3:19PM
 Batch: 00001.02.2026 - 02022026



Invoice No	Description	Amount	Pmt Date	Acct Number	Reference
Vendor: 2320	ACOUSTIC AVENUE			Check Sequence: 1	ACH Enabled: False
Facade Program	Storefront Facade Program 6354 Main St	3,408.75	01/30/2026	201-46500-50430	
	Check Total:	3,408.75			
Vendor: 1646	Ameritas			Check Sequence: 2	ACH Enabled: False
0130 AMER	01/30/2026 PAYROLL	90.00	01/30/2026	101-00000-21705	
	Check Total:	90.00			
Vendor: 1092	CENTRAL PENSION FUND			Check Sequence: 3	ACH Enabled: False
JAN 2026	CENTRAL PENSION	7,903.94	01/30/2026	101-00000-21705	
	Check Total:	7,903.94			
Vendor: UB*00113	JILL DESROSIER			Check Sequence: 4	ACH Enabled: False
	Refund Check 012847-000, 4690 382ND DR	6.13	01/27/2026	615-00000-20200	
	Refund Check 012847-000, 4690 382ND DR	8.03	01/27/2026	602-00000-20200	
	Refund Check 012847-000, 4690 382ND DR	0.25	01/27/2026	615-00000-20200	
	Refund Check 012847-000, 4690 382ND DR	4.45	01/27/2026	602-00000-20200	
	Refund Check 012847-000, 4690 382ND DR	5.20	01/27/2026	615-00000-20200	
	Refund Check 012847-000, 4690 382ND DR	1.91	01/27/2026	612-00000-20200	
	Check Total:	25.97			
Vendor: UB*00107	DUE NORTH HOMES LLC			Check Sequence: 5	ACH Enabled: False
	Refund Check 013495-000, 38946 7TH AVE UT	74.56	01/27/2026	602-00000-20200	
	Check Total:	74.56			
Vendor: UB*00114	DUE NORTH HOMES LLC			Check Sequence: 6	ACH Enabled: False

Invoice No	Description	Amount	Pmt Date	Acct Number	Reference
	Refund Check 013483-000, 38946 7TH AVE UT	74.64	01/27/2026	602-00000-20200	
	Check Total:	74.64			
Vendor: 1152	EHLERS			Check Sequence: 7	ACH Enabled: False
MN PUB FIN	PUBLIC FINANCE SEMINAR	350.00	01/30/2026	101-41500-50332	
	Check Total:	350.00			
Vendor: UB*00110	CHRISTINA FASHNER			Check Sequence: 8	ACH Enabled: False
	Refund Check 012084-000, 38632 OAKVIEW /	10.01	01/27/2026	612-00000-20200	
	Refund Check 012084-000, 38632 OAKVIEW /	0.59	01/27/2026	615-00000-20200	
	Refund Check 012084-000, 38632 OAKVIEW /	1.27	01/27/2026	615-00000-20200	
	Refund Check 012084-000, 38632 OAKVIEW /	23.30	01/27/2026	602-00000-20200	
	Refund Check 012084-000, 38632 OAKVIEW /	0.92	01/27/2026	602-00000-20200	
	Refund Check 012084-000, 38632 OAKVIEW /	32.14	01/27/2026	615-00000-20200	
	Check Total:	68.23			
Vendor: UB*00109	KAREN HERMANN			Check Sequence: 9	ACH Enabled: False
	Refund Check 007831-000, 38125 FIELDSTON	1.06	01/27/2026	615-00000-20200	
	Refund Check 007831-000, 38125 FIELDSTON	0.78	01/27/2026	615-00000-20200	
	Refund Check 007831-000, 38125 FIELDSTON	1.64	01/27/2026	602-00000-20200	
	Refund Check 007831-000, 38125 FIELDSTON	19.22	01/27/2026	615-00000-20200	
	Refund Check 007831-000, 38125 FIELDSTON	5.99	01/27/2026	612-00000-20200	
	Refund Check 007831-000, 38125 FIELDSTON	13.93	01/27/2026	602-00000-20200	
	Check Total:	42.62			
Vendor: 1176	M Health Fairview			Check Sequence: 10	ACH Enabled: False
15008914701	VISIT 15008914701 ON 12/18/2025	116.00	01/30/2026	615-49550-50406	
15008921574	VISIT 15008921574 ON 12/22/2025	35.00	01/30/2026	101-43000-50406	
15008921685	VISIT 15008921685 ON 12/22/2025	35.00	01/30/2026	615-49550-50406	
15008923248	VISIT 15008923248 ON 12/22/2025	116.00	01/30/2026	101-43000-50406	
	Check Total:	302.00			
Vendor: UB*00111	WAYNE RUFFCORN			Check Sequence: 11	ACH Enabled: False
	Refund Check 012784-000, 4986 382ND DR	0.45	01/27/2026	615-00000-20200	

Invoice No	Description	Amount	Pmt Date	Acct Number	Reference
	Refund Check 012784-000, 4986 382ND DR	10.99	01/27/2026	615-00000-20200	
	Refund Check 012784-000, 4986 382ND DR	2.83	01/27/2026	615-00000-20200	
	Refund Check 012784-000, 4986 382ND DR	4.38	01/27/2026	602-00000-20200	
	Refund Check 012784-000, 4986 382ND DR	7.97	01/27/2026	602-00000-20200	
	Refund Check 012784-000, 4986 382ND DR	3.42	01/27/2026	612-00000-20200	
	Check Total:	30.04			
Vendor: UB*00108	DAWSON VAN DELIST & EMILY SANFORD			Check Sequence: 12	ACH Enabled: False
	Refund Check 007143-000, 37982 GERALD A	1.92	01/27/2026	615-00000-20200	
	Refund Check 007143-000, 37982 GERALD A	47.65	01/27/2026	615-00000-20200	
	Refund Check 007143-000, 37982 GERALD A	34.55	01/27/2026	602-00000-20200	
	Refund Check 007143-000, 37982 GERALD A	0.15	01/27/2026	602-00000-20200	
	Refund Check 007143-000, 37982 GERALD A	14.86	01/27/2026	612-00000-20200	
	Refund Check 007143-000, 37982 GERALD A	0.07	01/27/2026	615-00000-20200	
	Check Total:	99.20			
Vendor: UB*00112	KELSEY VICHOREK			Check Sequence: 13	ACH Enabled: False
	Refund Check 009672-000, 37830 HARVESTE	0.52	01/27/2026	615-00000-20200	
	Refund Check 009672-000, 37830 HARVESTE	14.36	01/27/2026	612-00000-20200	
	Refund Check 009672-000, 37830 HARVESTE	0.79	01/27/2026	602-00000-20200	
	Refund Check 009672-000, 37830 HARVESTE	1.89	01/27/2026	615-00000-20200	
	Refund Check 009672-000, 37830 HARVESTE	46.10	01/27/2026	615-00000-20200	
	Refund Check 009672-000, 37830 HARVESTE	33.42	01/27/2026	602-00000-20200	
	Check Total:	97.08			
Vendor: 1865 TIF 2018-01	Willow Grove of North Branch, Ltd Partnership TIF 2018-1 WILLOW GROVE	2,520.62	01/30/2026	Check Sequence: 14 291-46500-50454	ACH Enabled: False
	Check Total:	2,520.62			
Vendor: UB*00063	KYLE YOUNG			Check Sequence: 15	ACH Enabled: False
	Refund Check 005000-000	1.49	01/30/2026	615-00000-20200	
	Refund Check 005000-000	26.69	01/30/2026	615-00000-20200	
	Refund Check 005000-000	41.22	01/30/2026	602-00000-20200	
	Refund Check 005000-000	11.45	01/30/2026	612-00000-20200	

Invoice No	Description	Amount	Pmt Date	Acct Number	Reference
	Refund Check 005000-000	26.58	01/30/2026	602-00000-20200	
	Refund Check 005000-000	0.49	01/30/2026	615-00000-20200	
	Refund Check 005000-000	36.71	01/30/2026	615-00000-20200	
	Check Total:	144.63			
	Total for Check Run:	15,232.28			
	Total of Number of Checks:	15			

Accounts Payable

Checks by Date - Summary by Check Number

User: TiffaniFolstad
Printed: 2/4/2026 2:30 PM



Check No	Vendor No	Vendor Name	Check Date	Check Amount
6056	1365	Minnesota Energy Resources	01/16/2026	7,720.45
6057	1592	US Postal Service	01/27/2026	1,187.80
6058	1818	Old National Bank	01/28/2026	162,819.15
6059	1424	N.B. Fire Relief Association	01/30/2026	492.80
6060	1118	Commissioner Of Revenue (W/H)	02/03/2026	9,680.38
6061	1468	PERA (Payroll W/H)	02/03/2026	37,890.71
6062	1585	United States Treasury	02/03/2026	41,871.52
6063	1372	Minnesota State Retirement	02/03/2026	2,782.85
6064	2236	Delta Dental	01/06/2026	2,782.73
6065	1585	United States Treasury	01/16/2026	43,732.59
6066	1468	PERA (Payroll W/H)	01/16/2026	40,766.93
6067	1362	MINNESOTA REVENUE	01/16/2026	37,778.00
6068	1118	Commissioner Of Revenue (W/H)	01/16/2026	10,171.45
6069	1993	Truist Government Finance	02/01/2026	30,478.00
6070	1372	Minnesota State Retirement	01/16/2026	2,738.12
Report Total (15 checks):				432,893.48



NORTH BRANCH

—Minnesota—

Kevin Schieber
Mayor

Robert Canada
Councilmember/Acting Mayor

Jeff Goulet
Councilmember

Jim Ibinger
Councilmember

Patrick Meacham
Councilmember

**CITY COUNCIL
REGULAR AGENDA
TUESDAY, JANUARY 27, 2026 @ 7:00 PM
CITY HALL, 6408 ELM STREET, NORTH
BRANCH, MN 55056**

MINUTES OF THE PROCEEDINGS OF THE CITY COUNCIL OF THE CITY OF NORTH BRANCH IN THE COUNTY OF CHISAGO AND IN THE STATE OF MINNESOTA

REGULAR MEETING

Tuesday, January 27, 2026

1. CALL TO ORDER

Mayor Kevin Schieber called the North Branch City Council meeting to order at 7:00 PM

2. PLEDGE OF ALLEGIANCE

Mayor Kevin Schieber led the Pledge of Allegiance.

3. ROLL CALL

Present: Mayor Kevin Schieber, Councilmember Jeff Goulet, Councilmember Jim Ibinger, Councilmember Patrick Meacham, Councilmember Robert Canada

Absent:

Remote:

Others Present:

Notes:

4. AGENDA APPROVAL

a. Approve Agenda

ACTION

RESULT: Passed

MOVER: Kevin Schieber

SECONDER: Robert Canada

AYES: Kevin Schieber, Jeff Goulet, Jim Ibinger, Patrick Meacham, Robert Canada

ABSENT:

NOTES:

5. PRESENTATION & PROCLAMATION

- a. Chisago County presentation of the Roundabout at Hemingway Avenue and Lincoln Trail (CoRd 14) INFO

Chisago County Public Works Director Joe Triplett and Ben Holbert from Chisago County gave a presentation about the County Road 14 Roundabout Project at Hemingway Avenue and Lincoln Trail (County Road 14).

- b. North Branch Schools presents information about the February 10 vote to renew the Capital Projects Levy. INFO

North Branch Schools Superintendent Sara Paul presented information about the February 10th vote at Main Street Church to renew the Capital Projects Levy.

6. PUBLIC COMMENT

Provides an opportunity for the public to address the Council on items that are not on the Agenda. Please raise your hand to be recognized. Please state your name and address for the record. This section is for the express purpose of addressing concerns of City services and operations. It shall not be used to clarify individual's views for political purposes.

7. CONSENT AGENDA

All matters listed under Consent Agenda are considered routine and/or non-controversial and will be approved by one motion. There will be no separate discussion of these items unless a Councilmember or citizen so requests, in which case the item will be removed from the Consent Agenda and considered in its normal sequence on the Agenda.

City Councilmember Jeff Goulet made a comment that he has no objections to Ordinance Amendment 406-25, to change the days and times of the City Council meetings to the 2nd and 4th Wednesdays of each month at 6 PM, but that it will be a slightly tighter schedule-wise, and that there may be some conflicts in the future.

RESULT: Passed
MOVER: Robert Canada
SECONDER: Jim Ibinger
AYES: Kevin Schieber, Jeff Goulet, Jim Ibinger, Patrick Meacham, Robert Canada
ABSENT:
NOTES:

- a. Claims ACTION
- b. Approval of Minutes - Regular Council Meeting - January, 13, 2026, 7:00 PM ACTION
- c. Approve the LG240B Application to Conduct Excluded Bingo - St. Gregory Knights of Columbus Council 10016 ACTION
- d. Approve Gambling LG220 for Exempt Permit - Full Count ACTION
- e. Approve Gambling LG220 Permit - North Branch American Legion Riders Post 85 ACTION
- f. Approve 2026 Massage Therapists Licenses - Shauna Lopez and Tiffany Christian ACTION
- g. Approval of Road Maintenance Agreement with Stacy MN ACTION
- h. Approval of Ordinance Amendment #406-26 to change the days and times of the City Council meetings to the 2nd and 4th Wednesdays of each month at 6:00pm. ACTION

- i. Approval of the Ordinance Amendment 408-26 to add low-potency hemp products ACTION to the list of required licensing fees to our fee schedule.
- j. Approval of Contract with BS&A Software for 2026 Implementation ACTION
- k. Approval of Resolution R-285-2026 approving a Conditional Use Permit for a Wireless Communications Tower at PID: 11.00223.00 ACTION

8. PUBLIC HEARINGS

9. STAFF REPORTS

- a. 2025 Police Department Activity Report INFO

Police Chief Dan Meyer presented the 2025 Police Department Activity Report. Our police department provides 24/7 police coverage and currently consists of 15 sworn officers, including the police chief, two patrol sergeants, one investigator, one school resource officer, and ten patrol officers. In addition to our sworn staff, we have an office manager and an administrative assistant, along with four volunteer police reserve officers.

During 2025, the police department handled a total of 16,030 incidents/calls for service. Our department issued 538 citations and made 162 arrests during the calendar year. Our police reserve unit also volunteered 911 hours last year, helping out at our community events and assisting our sworn staff on calls such as medicals, public assists, vehicle lockouts, motor vehicle crashes, and prisoner transport.

We continue to expand and build upon our community engagement initiatives. We were involved with several community events during 2025, which included:

- North Branch High School Career Fair (May)
- North Branch Area Schools Vehicle Fair (May)
- North Branch American Legion Annual Midsummer Days Celebration (June)
- Bike MS: MS150 MN 2025 (June)
- Annual "Walk and Roll to School" Events (May and October)
- Law Enforcement Special Olympics Torch Run (June)
- Coffee/Cone/Cocoa with a Cop Events (July and December)
- Night to Unite (August)
- North Branch Area Chamber's Fall Harvest Festival (September)
- NBHS Homecoming Parade and Events (September)
- Special Olympics Truck Convoy (October)
- Chisago County Operation Community Connect (October)
- North Branch Arts Fest 2025 (November)
- McDonald's McHero Night (November)
- Annual "Stuff the Squad" Event at County Market (November)
- Public Safety Parade and Christmas Tree Lighting Ceremony (December)

- b. Consider Resolution R-284-2026 approving a variance from minimum lot depths ACTION for Lots 5-7, Block 2, Fairway Field

City Planner, Ryan Saltis, presented the consideration of Resolution R-284-2026 approving a variance from minimum lot depths for Lots 5-7, Block 2, Fairway Field. Larry Beach Construction, Inc. (Applicant) has submitted a request for a Variance and preliminary plat approval for a new residential subdivision known as Fairway Field, located generally at the intersection of 412th Street and Flink Avenue. The Subject Property is currently undeveloped and is guided and zoned for Rural-Residential.

The Preliminary Plat proposes the creation of 13 residential lots (each exceeding 1 acre in lot size), new public streets, stormwater facilities, and associated utilities. Access to the subdivision

is provided via 412th Street with two new internal public roadways, including Fairfax Lane and Fairway Court, as shown on the Preliminary Plat and Site Plans. The applicant has applied for a variance from the required minimum lot depths for lots 5-7 within Block 2 of the plat due to irregularity in lot dimensions/shapes, road configurations, and elevations of the site.

The applicant has submitted a complete application, including preliminary plat drawings, grading and erosion control plans, utility plans, landscaping, and tree preservation. Final Plat approval is subject to City Council action and completion of all required conditions.

The Planning Commission held a public hearing on Tuesday, January 6, 2026, and received general comments regarding access, lot size, density and groundwater impacts. The Planning Commission recommended approval (4-0) of the variance for a reduction in minimum lot depths for the Fairway Field development with the following conditions.

- The minimum lot depths for Block 2, Lots 5, 6, and 7 must be at least 200 feet.

Motion to approve Resolution R-284-2026 approving a variance from minimum lot depths for Lots 5-7, Block 2, Fairway Field.

RESULT: Passed
MOVER: Jeff Goulet
SECONDER: Robert Canada
AYES: Kevin Schieber, Jeff Goulet, Jim Ibinger, Patrick Meacham, Robert Canada
ABSENT:
NOTES:

c. Consider Approval of Resolution R-283-2026 approving the Fairway Field Preliminary Plat ACTION

City Planner, Ryan Saltis, presented the consideration of approval of Resolution R-283-2026 approving the Fairway Field Preliminary Plat. Larry Beach Construction, Inc. (Applicant) has submitted a request for Preliminary Plat and Variance approval for a new residential subdivision known as Fairway Field, located generally at the intersection of 412th Street and Flink Avenue. The Subject Property is currently undeveloped and is guided and zoned for Rural-Residential.

The Preliminary Plat proposes the creation of 13 residential lots (each exceeding 1 acre in lot size), new public streets, stormwater facilities, and associated utilities. Access to the subdivision is provided via 412th Street with two new internal public roadways, including Fairfax Lane and Fairway Court, as shown on the Preliminary Plat and Site Plans. The applicant has also applied for a variance from the required lot depths for lots within Block 2 of the plat.

The applicant has submitted a complete application, including preliminary plat drawings, grading and erosion control plans, utility plans, landscaping, and tree preservation. Final Plat approval is subject to City Council action and completion of all required conditions.

The Planning Commission held a public hearing on Tuesday, January 6, 2026, and received general comments regarding access, lot size, and density. The Planning Commission recommended approval (4-0) of the preliminary plat for Fairway Field with the following conditions.

1. The Applicant shall address and comply with the City Engineer's memo dated December 2, 2025.
2. All public improvements shall be constructed in accordance with City of North Branch standards.

3. A Development Agreement shall be executed prior to Final Plat approval.

Motion to approve Resolution R-283-2026 approving the Fairway Field Preliminary Plat.

RESULT: Passed
MOVER: Jeff Goulet
SECONDER: Robert Canada
AYES: Kevin Schieber, Jeff Goulet, Jim Ibinger, Patrick Meacham, Robert Canada
ABSENT:
NOTES:

d. Human Resource Report INFO

The Human Resource Generalist gave the Human Resource Report. The last few months have been busy for Human Resources. We onboarded four new employees. Matt Fraley started as the Director of Public Works and Utilities in December. We also brought on board Jessica, Ella, and Ryan as Warming House Attendants. Two employees are currently on leave, and we are looking forward to their return this spring. Angela Tveit resigned from her position, and her last day was January 16th. We appreciate her three years of service to the City of North Branch.

The close of 2025 saw a change in our employees' insurance plan. I do want to recognize all the employees for their timely response and communication, which allowed us to be able to make this change in a short amount of time.

The fire department is currently interviewing applicants to join their team. We will be starting interviews for an Administrative Assistant in the next few weeks. Currently, we have postings for a Police Officer and a Building Official. I would also like to highlight the staff's ongoing commitment to learning through continuing education. In 2026, among all departments, we have a combined 30 classes that staff members signed up for. Courses range from maintaining the safety of drinking water to planning and emergency response. All these classes ensure the staff maintain their required certifications.

e. Consider Council Consensus on 2026 Equipment Bond ACTION

Finance Director Sharon Wright presented the 2026 Equipment Bond. Over the past several months, the City has been evaluating the potential issuance of an Equipment Bond. Multiple structuring options are available, and City staff is requesting guidance regarding both the bond structure and the total amount to be issued.

Bond Structure

One option is to structure the Equipment Bond so that principal payments begin after the final payment on the 2022 Equipment Bond, which is scheduled to be completed in 2032. Under this approach, principal payments on the proposed 2026 Equipment Bond would be deferred until that time. While this structure would result in higher total interest costs over the life of the bond, it would maintain debt service payments at levels consistent with the City's current obligations. An alternative structure would require principal payments to begin immediately upon issuance of the bond. This option would reduce total interest costs but would increase near-term debt service payments, resulting in higher annual expenditures during the initial years of the bond.

Bond Amount

The total amount of Equipment Bonds to be issued will depend on which equipment is ultimately selected for funding through this financing method. During the December 9, 2025 meeting, City Council directed staff to proceed with financing the Fire Department ladder truck and three (3) Public Works snow plows through the Equipment

Bond, for a total amount of \$2,050,000. This is the first option presented.

The second option includes additional equipment purchases consisting of a one-ton truck and a mini-excavator for the Water Fund; a Fire Department tanker truck; and, for the Public Works Department, a front-end loader and a one-ton four-wheel-drive plow truck. The total cost of these items is \$1,345,000. When combined with the first option, the total amount of Equipment Bonds issued would be \$3,395,000.

The final equipment option under consideration includes a half-ton four-wheel-drive pickup and a three-quarter-ton cargo van for the Public Works Department, as well as a three-quarter-ton pickup for the Sewer Fund. The total cost of these items is \$220,000. The two pickup trucks have an estimated useful life of ten (10) years, while the cargo van has an estimated useful life of fifteen (15) years.

Financing for these three items may be structured in one of two ways. First, the City could utilize an interfund loan from the Generation Fund to fund these purchases. An advantage of this approach is that interest payments would remain within the City, as interest paid by the borrowing funds would offset interest earnings otherwise forgone by the Generation Fund.

Alternatively, these items could be included in the Equipment Bond issuance, resulting in a total bond amount of \$3,615,000.

Consensus was for the total amount of the bond to be \$3,075,000.

10. MAYOR/CITY COUNCIL

- a. Notice of Local Board of Appeal and Equalization meeting - Thursday, April 16, 2026, 6:00pm at North Branch City Hall INFO

The Local Board of Appeal and Equalization meeting will be held on Thursday, April 16, 2026 at 6:00 PM at the North Branch City Hall. Two assessors from the County will be in attendance to support any questions that people might have in regards to their evaluations for 2027.

- b. Cannabis Ordinance Review

VERBAL
UPDATE

City Administrator Matthew Hill presented the Cannabis Ordinance Review. It was the consensus of the City Council to review City Ordinance No. 381-24 to address specific concerns raised during the recent license approval process and provide direction to staff on any necessary amendments or clarifications.

City Ordinance No. 381-24 was adopted on September 24, 2024. Discussion at the October 2025 Council meetings brought up questions regarding:

- Clarity on Buffer Zones: Potential ambiguity in the measurement or application of distance requirements from sensitive uses (e.g., schools, parks, and daycare facilities).

The purpose of this review is to provide an opportunity for the City Council to receive the existing Ordinance, address the specific items of concern identified in October 2025, and provide policy direction to staff. The outcome of this discussion may include a directive to the City Attorney to draft amendments to the Ordinance.

Consensus was for Councilmember Canada to come back to the Council with some recommended changes that they can discuss further.

c. Advisory Committee reports

VERBAL
UPDATE

Councilmember Canada gave a Public Safety update. The Fire Chief went to the Minnesota State Fire Chiefs Association, and different Fire Chiefs complimented the North Branch firefighters. A group of City of North Branch firefighters drove to Chicago to look at a ladder truck that is for sale. The Fire Department is looking at some new signage in front of the fire hall and is trying to incorporate the bell that has been currently used. The Chief and HR are exploring the possibility of offering counseling services to the Police and Fire Department.

Councilmember Goulet gave a Finance update regarding the liquor store, saying sales have been a little soft, but their cost management side has been keeping the profit coming in. For Public Works, 2026 projects are being discussed. The Old Town Street and utility project was pushed out until 2027. The Viking Meadows development utility extension will be postponed until 2027. There were also quite a few applicants for the Public Works Administrative Specialist position.

Councilmember Ibinger mentioned that we kind of discussed the Finance Advisory Committee information with the bonding. We haven't had an official liquor store advisory committee meeting since November, so it would be good to get one of those on the books.

City Administrator Matthew Hill discussed that the water and light building had a fire last Sunday evening. There is extensive damage to the roof and to the mechanical equipment within that facility. The inspectors are coming up to take a look at it, but they estimate that the ceiling caught fire from the exhaust system.

Mayor Kevin Schieber gave a quick Parks, Trails, and Open Spaces update. The Christmas lights look great, both on the trees and on the streets. The Commission talked about vendors coming in for Concerts in the Parks and hoping to get more vendors. The Parks, Trails, and Open Spaces Commission is in the process of receiving 40 acres from the Max Malmquist property and figuring out exactly what that's going to look like. Most of the mayors throughout Chisago County got together to meet. A large part of the discussion was on local control and the state trying to mandate some of the City requirements, such as zoning and high density. There is a 2nd meeting tomorrow with Senator Koran and Representative Rymer.

Councilmember Meacham gave an update regarding the Planning Commission. We're going to have a public hearing on cleaning up two areas of code. The requirement to have paved driveways, and currently looking back, it is written that the surfacing section only specifies paving requirements for residential properties that are 2 acres or smaller. There are some questions about whether it's required in commercial or industrial developments, and if they should be paved. In the Planning Commission, we're talking about it because 2 acres doesn't line up with residential minimums. The conversation got into allowing some side parking areas for your recreational vehicles. For the EDA, Nancy Hoffman said that the retail trade analysis is completed, and the presentation is going to be on February 19th at the Senior Center from 2-4 pm. Director Nathan Sondrol brought up during the EDA meeting is an initial drawing of the potential or the replanting proposal of the business park with LP coming in.

11. ADJOURNMENT

The City Council meeting adjourned at 8:51 PM.



Prepared By: Tonya Kostuch, City Clerk

Presenter: Tonya Kostuch, City Clerk

Date: 02/04/2026

Board & Commission: City Council

Subject: Approve Gambling LG220 Exempt Permit - NWTF Long Spurs of Sunrise River

Background Information:

The NWTF Long Spurs of Sunrise River will be holding a Bingo and Raffle at the North Branch Legion, Post 85 at 6439 Elm Street, North Branch, MN 55056 on March 18th, 2026. The clerk's office signs off on the application before the requester can send it to the Minnesota Alcohol & Gambling Enforcement office, so they can be issued a permit to carry out such an event as requested after City Council approval.

Staff Recommendation & Requested City Council Action:

Staff recommends Council to approve the application for submission to the Minnesota Gambling Control Board by NWTF Long Spurs of Sunrise River.

Voting Requirements:

Voting Options Simple Majority

LG220 Application for Exempt Permit

An exempt permit may be issued to a nonprofit organization that:

- conducts lawful gambling on five or fewer days, and
- awards less than \$50,000 in prizes during a calendar year.

If total raffle prize value for the calendar year will be \$1,500 or less, contact the Licensing Specialist assigned to your county by calling 651-539-1900.

Application Fee (non-refundable)

Applications are processed in the order received. If the application is postmarked or received 30 days or more before the event, the application fee is **\$100**; otherwise the fee is **\$150**.

Due to the high volume of exempt applications, payment of additional fees prior to 30 days before your event will not expedite service, nor are telephone requests for expedited service accepted.

ORGANIZATION INFORMATION

Organization Name: NWTF Long Spurs of Sunrise River Previous Gambling Permit Number: X _____

Minnesota Tax ID Number, if any: _____ Federal Employer ID Number (FEIN), if any: _____

Mailing Address: _____

City: North Branch State: MN Zip: 55056 County: Chisago

Name of Chief Executive Officer (CEO): Lance Morgan

CEO Daytime Pho: _____ CEO Email: _____
(permit will be emailed to this email address unless otherwise indicated below)

Email permit to (if other than the CEO) _____

NONPROFIT STATUS

Type of Nonprofit Organization (check one):

- Fraternal Religious Veterans Other Nonprofit Organization

Attach a copy of one of the following showing proof of nonprofit status:

(DO NOT attach a sales tax exempt status or federal employer ID number, as they are not proof of nonprofit status.)

- A current calendar year Certificate of Good Standing**
Don't have a copy? Obtain this certificate from:
MN Secretary of State, Business Services Division Secretary of State website, phone numbers:
60 Empire Drive, Suite 100 www.sos.state.mn.us
St. Paul, MN 55103 651-296-2803, or toll free 1-877-551-6767
- IRS income tax exemption (501(c)) letter in your organization's name**
Don't have a copy? To obtain a copy of your federal income tax exempt letter, have an organization officer contact the IRS toll free at 1-877-829-5500.
- IRS - Affiliate of national, statewide, or international parent nonprofit organization (charter)**
If your organization falls under a parent organization, attach copies of both of the following:
1. IRS letter showing your parent organization is a nonprofit 501(c) organization with a group ruling; and
2. the charter or letter from your parent organization recognizing your organization as a subordinate.

GAMBLING PREMISES INFORMATION

Name of premises where the gambling event will be conducted (for raffles, list the site where the drawing will take place): North Branch Legion Post 25

Physical Address (do not use P.O. box): 6439 Elm St North

Check one:
 City: North Branch Zip: 55056 County: Chisago
 Township: _____ Zip: _____ County: _____

Date(s) of activity (for raffles, indicate the date of the drawing): March 18th 2026

Check each type of gambling activity that your organization will conduct:

- Bingo Paddlewheels Pull-Tabs Tipboards Raffle

Gambling equipment for bingo paper, bingo boards, raffle boards, paddlewheels, pull-tabs, and tipboards must be obtained from a distributor licensed by the Minnesota Gambling Control Board. EXCEPTION: Bingo hard cards and bingo ball selection devices may be borrowed from another organization authorized to conduct bingo. To find a licensed distributor, go to www.mn.gov/gcb and click on **Distributors** under the **List of Licensees** tab, or call 651-539-1900.

LOCAL UNIT OF GOVERNMENT ACKNOWLEDGMENT (required before submitting application to the Minnesota Gambling Control Board)

<p style="text-align: center;">CITY APPROVAL for a gambling premises located within city limits</p> <p><input type="checkbox"/> The application is acknowledged with no waiting period.</p> <p><input type="checkbox"/> The application is acknowledged with a 30-day waiting period, and allows the Board to issue a permit after 30 days (60 days for a 1st class city).</p> <p><input type="checkbox"/> The application is denied.</p> <p>Print City Name: _____</p> <p>Signature of City Personnel: _____</p> <p>Title: _____ Date: _____</p> <div style="border: 1px solid black; padding: 5px; text-align: center; margin-top: 10px;"> <p>The city or county must sign before submitting application to the Gambling Control Board.</p> </div>	<p style="text-align: center;">COUNTY APPROVAL for a gambling premises located in a township</p> <p><input type="checkbox"/> The application is acknowledged with no waiting period.</p> <p><input type="checkbox"/> The application is acknowledged with a 30-day waiting period, and allows the Board to issue a permit after 30 days.</p> <p><input type="checkbox"/> The application is denied.</p> <p>Print County Name: _____</p> <p>Signature of County Personnel: _____</p> <p>Title: _____ Date: _____</p> <p>TOWNSHIP (if required by the county) On behalf of the township, I acknowledge that the organization is applying for exempted gambling activity within the township limits. (A township has no statutory authority to approve or deny an application, per Minn. Statutes, section 349.213.)</p> <p>Print Township Name: _____</p> <p>Signature of Township Officer: _____</p> <p>Title: _____ Date: _____</p>
--	---

CHIEF EXECUTIVE OFFICER'S SIGNATURE (required)

The information provided in this application is complete and accurate to the best of my knowledge. I acknowledge that the financial report will be completed and returned to the Board within 30 days of the event date.

Chief Executive Officer's Signature: Lance Morgan Date: 2/3/26
(Signature must be CEO's signature; designee may not sign)

Print Name: Lance Morgan

<p>REQUIREMENTS</p> <p>Complete a separate application for:</p> <ul style="list-style-type: none"> • all gambling conducted on two or more consecutive days; or • all gambling conducted on one day. <p>Only one application is required if one or more raffle drawings are conducted on the same day.</p> <p>Financial report to be completed within 30 days after the gambling activity is done: A financial report form will be mailed with your permit. Complete and return the financial report form to the Gambling Control Board.</p> <p>Your organization must keep all exempt records and reports for 3-1/2 years (Minn. Statutes, section 349.166, subd. 2(f)).</p>	<p>MAIL APPLICATION AND ATTACHMENTS</p> <p>Mail application with:</p> <p>_____ a copy of your proof of nonprofit status; and</p> <p>_____ application fee (non-refundable). If the application is postmarked or received 30 days or more before the event, the application fee is \$100; otherwise the fee is \$150. Make check payable to State of Minnesota.</p> <p>To: Minnesota Gambling Control Board 1711 West County Road B, Suite 300 South Roseville, MN 55113</p> <p>Questions? Call the Licensing Section of the Gambling Control Board at 651-539-1900.</p>
--	--

<p>Data privacy notice: The information requested on this form (and any attachments) will be used by the Gambling Control Board (Board) to determine your organization's qualifications to be involved in lawful gambling activities in Minnesota. Your organization has the right to refuse to supply the information; however, if your organization refuses to supply this information, the Board may not be able to determine your organization's qualifications and, as a consequence, may refuse to issue a permit. If your organization supplies the information requested, the Board will be able to process the</p>	<p>application. Your organization's name and address will be public information when received by the Board. All other information provided will be private data about your organization until the Board issues the permit. When the Board issues the permit, all information provided will become public. If the Board does not issue a permit, all information provided remains private, with the exception of your organization's name and address which will remain public. Private data about your organization are available to Board members, Board staff whose work requires access to the information; Minnesota's Depart-</p>	<p>ment of Public Safety; Attorney General; Commissioners of Administration, Minnesota Management & Budget, and Revenue; Legislative Auditor, national and international gambling regulatory agencies; anyone pursuant to court order; other individuals and agencies specifically authorized by state or federal law to have access to the information; individuals and agencies for which law or legal order authorizes a new use or sharing of information after this notice was given; and anyone with your written consent.</p>
---	--	--

This form will be made available in alternative format (i.e. large print, braille) upon request.



Prepared By: Matthew Hill, City Administrator

Presenter: Matthew Hill, City Administrator

Date: 01/27/2026

Board & Commission: City Council

Subject: Approval of Resolution R-287-2026 Authorizing Payment For Pay Request #8 for CoRd 30 Street Improvement Project

The County Road 30 reconstruction and trail project is complete and Chisago County has submitted pay request #8 for this project. This is not the final as there will be some punch list items to be addressed in the spring. 3% retainage has been withheld.

The quantities completed to date have been reviewed and agreed upon by Chisago County and the Contractor and our engineering firm WSB, and have recommended the approval of construction pay voucher No. 8 for Chisago County in the amount of \$26,729.52.

Project Background:

The City partnered with Chisago County for the construction of a trail and crosswalk improvements along the west side of CSAH 30 from Maple Street to 377th Street and a roundabout improvement at the intersection of CSAH 30 and 377th Street. These improvements are included as part of the overall CSAH 30 Improvement project from Maple Street to Co Rd 17.

The City Council approved a letter of understanding (LOU) between Chisago County and the City for the project that outlined the roles and responsibilities for each entity for the project at the September 24, 2024, meeting and approved the plans and specs and authorized obtaining bids at the same meeting. Chisago County obtained bids and awarded Knife River Corporation the contract with the low quote for the project in the amount of \$6,586,316.60. The City Council approved the award of the low bid and the city's contribution to the project at the October 26, 2024 meeting with the

City's contribution for the project would be \$1,718,103.56 with a breakdown of the costs below. The project is bid on unit quantities and final project cost will be based on actual quantities used. The city requires a 5% contingency for all projects. The funding for the project was identified in the 2025 budget discussions and through srts grant funding.

CSAH 30 SRTS and CITY COSTS
Total \$1,718,103.56 Funding Source
City \$1,145,628.06 Reserves
SRTS \$322,475.50 Grant
Developer \$250,000.00 Developer

The developer conducted an EAW for the Townsedge development that required the installation of turn lanes on CSAH 30 to the development. The developer has agreed to contribute funds to the cost of the construction of the roundabout in lieu of the installation of the turn lanes.

Requested Action:
Approve Resolution R-287-2026 approving the CSAH 30 (Forest Blvd & SRTS Trail Project)
Pay Request #8 to Chisago County in the amount of \$26,728.52.

Voting Requirements:

Voting Options Simple Majority

STATE OF MINNESOTA

COUNTY OF CHISAGO

CITY OF NORTH BRANCH

CITY COUNCIL RESOLUTION NO. R-287-2026

Resolution R-287-2026 Approving Co.Rd. 30 Project Pay Request #8

WHEREAS, pursuant to City Council Authorization on February 11, 2025 this project was approved, and the project was awarded to Knife River Corporation and the city is partnering with Chisago County Public Works on this project, and the city cost for this project will be \$1,718,103.56 with the city funding break down is as follows, received a safe routes to school grant in the amount of \$250,000.00,, the developer Graphic Homes Inc. will pay \$250,000, and the balance of \$1,145,628.06 will come from city reserves, and

WHEREAS, Chisago County has submitted pay voucher no.8 in the amount \$26,728.52, and the quantities have been reviewed and approved by both the contractor, Chisago County, and the City's Engineer WSB and Associates as accurate.

Now, Therefore, Be It Resolved That: The City of North Branch Council approves Pay Request Number 8 in the amount of \$26,728.52 to Chisago County as outlined in the said report for the Co.Rd. 30 reconstruction and trail project.

ADOPTED this 11th day of February 2026.

Approved:

Kevin Schieber, Mayor

Attested:

Tonya Kostuch, City Clerk



January 27, 2026

Mr. Matthew Hill
City of North Branch
PO Box 910
North Branch, MN 55056

Re: CSAH 30 (Forest Blvd) & Safe Routes to School Trail Project
City of North Branch, MN
WSB Project No. 021646-000

Dear Mr. Hill:

Enclosed is Construction Pay Voucher No. 8 for the CSAH 30 (Forest Blvd) & Safe Routes to School Trail Project. Chisago County and the contractor have reviewed and agreed on the completed quantities, and we recommend that the City of North Branch pay Chisago County Finance \$26,728.52 for its share.

This payment includes certified work up to October 27, 2025, with retainage lowered to 3% due to substantial completion or major tasks being finished. If you have any questions or feedback, feel free to reach out to me at 612.388.9652.

Sincerely,

WSB

Justin Messner PE
Director, Municipal Services

Attachments

178 E 9TH STREET | SUITE 200 | SAINT PAUL, MN | 55101 | 651.286.8450 | WSBENG.COM

CSAH 30 Improvements - Pay Voucher #8

Item No.	Description	Unit	Unit Price	50% CHISAGO COUNTY SAP 013-630-021 50% CITY OF NORTH BRANCH SAP 225-102-004						SAP 225-591-007 CITY OF NORTH BRANCH			CITY OF NORTH BRANCH				
				NORTH BRANCH TOTAL		ROADWAY			STORM SEWER			SAFE ROUTES TO SCHOOL					
				Contract Quantity	Total Cost	Contract Quantity	Quantity To Date	Amount To Date	Contract Quantity	Quantity To Date	Amount To Date	Contract Quantity	Quantity To Date	Amount To Date	Contract Quantity	Quantity To Date	Amount To Date
2021.501	MOBILIZATION	LUMP SUM	\$460,000.00	0.19	\$85,100.00	0.13	0.13	\$59,800.00	0.04	0.04	\$18,400.00	0.05	0.05	\$23,000.00	0.05	0.05	\$23,000.00
2051.501	MAINT AND RESTORATION OF HAUL ROADS	LUMP SUM	\$10,500.00														
2101.502	CLEARING	EACH	\$199.00	50.50	\$10,049.50	1	8	\$1,592.00				50	58	\$11,542.00			
2101.502	GRUBBING	EACH	\$199.00	50.50	\$10,049.50	1	8	\$1,592.00				50	59	\$11,741.00			
2101.505	CLEARING	ACRE	\$2,501.00	0.35	\$875.35	0.5	0.5	\$1,250.50				0.1	0.1	\$250.10			
2101.505	GRUBBING	ACRE	\$2,501.00	0.35	\$875.35	0.5	0.5	\$1,250.50				0.1	0.1	\$250.10			
2104.502	REMOVE BOX CULVERT	EACH	\$3,700.00														
2104.502	REMOVE BOX CULVERT END	EACH	\$3,700.00														
2104.502	REMOVE GATE VALVE AND BOX	EACH	\$1,800.00	3.00	\$5,400.00	2	4	\$7,200.00				2	2	\$3,600.00			
2104.502	REMOVE HYDRANT	EACH	\$1,500.00	3.00	\$4,500.00	2	2	\$3,000.00				2	2	\$3,000.00			
2104.502	REMOVE DELINEATOR / MARKER	EACH	\$175.00														
2104.502	REMOVE SIGN	EACH	\$25.00	2.50	\$62.50	1	1	\$25.00							2	2	\$50.00
2104.502	REMOVE LIGHT FOUNDATION	EACH	\$150.00	0.50	\$75.00	1	1	\$150.00									
2104.502	SALVAGE LIGHTING UNIT	EACH	\$635.32	0.50	\$317.66	1											
2104.502	SALVAGE SIGN	EACH	\$25.00														
2104.502	SALVAGE MAIL BOX SUPPORT	EACH	\$200.00	5.00	\$1,000.00	2	2	\$400.00							4	4	\$800.00
2104.503	SAWING CONCRETE PAVEMENT (FULL DEPTH)	LIN FT	\$6.00	12.00	\$72.00	24	24	\$144.00									
2104.503	SAWING BITUMINOUS PAVEMENT (FULL DEPTH)	LIN FT	\$1.90	110.00	\$209.00							70	160	\$304.00	40	431	\$818.90
2104.503	REMOVE PIPE CULVERTS	LIN FT	\$17.00	54.00	\$918.00	108	108	\$1,836.00									
2104.503	REMOVE WATER MAIN	LIN FT	\$15.00	110.00	\$1,650.00										110	142.5	\$2,137.50
2104.503	REMOVE CURB AND GUTTER	LIN FT	\$4.50	118.00	\$531.00							78	230	\$1,035.00	40	323	\$1,453.50
2104.503	REMOVE GUARDRAIL-PLATE BEAM	LIN FT	\$18.00														
2104.503	REMOVE STEEL CASING	LIN FT	\$10.00	100.00	\$1,000.00										100	100	\$1,000.00
2104.503	REMOVE TENSION CABLE GUARDRAIL	LIN FT	\$20.00														
2104.504	REMOVE PAVEMENT	SQ YD	\$2.00	1173.00	\$2,346.00	2346	2352	\$4,704.00									
2104.504	REMOVE CONCRETE DRIVEWAY PAVEMENT	SQ YD	\$2.75														
2104.504	REMOVE BITUMINOUS DRIVEWAY PAVEMENT	SQ YD	\$2.00	170.00	\$340.00							161	38	\$75.80	9	215	\$430.00
2104.504	REMOVE BITUMINOUS PAVEMENT	SQ YD	\$2.00	2005.50	\$4,011.00	2861	3535.4	\$7,070.80							575	979.2	\$1,958.40
2104.518	REMOVE BITUMINOUS WALK	SQ FT	\$2.00	5017.50	\$10,035.00	10035	10200	\$20,400.00									
2104.518	REMOVE CONCRETE WALK	SQ FT	\$2.00	733.00	\$1,466.00										733	991	\$1,982.00
2104.602	REMOVE SIGN SPECIAL	EACH	\$25.00	0.50	\$12.50	1	1	\$25.00									
2104.602	SALVAGE SIGN SPECIAL	EACH	\$25.00														
2104.602	SALVAGE SIGN PANEL SPECIAL	EACH	\$25.00														
2106.507	EXCAVATION - COMMON	CU YD	\$6.00	6667.50	\$40,005.00	4649	4649	\$27,894.00				3183	3181	\$19,086.00	1160	1240	\$7,440.00
2106.507	EXCAVATION - SUBGRADE	CU YD	\$8.50	2605.00	\$22,142.50	3510	3510	\$29,835.00							850	850	\$7,225.00
2106.507	SELECT GRANULAR EMBANKMENT (CV)	CU YD	\$11.50	3256.00	\$37,444.00	4794	4794	\$55,131.00							859	859	\$9,878.50
2106.507	SELECT GRANULAR EMBANKMENT MOD 10% (CV)	CU YD	\$11.50														
2106.507	COMMON EMBANKMENT (CV)	CU YD	\$8.00	8266.00	\$66,128.00	1278	1278	\$10,224.00				7288	7288	\$58,304.00	339	379	\$3,032.00
2106.601	DEWATERING	LUMP SUM	\$42,000.00														
2130.523	WATER	M GALLON	\$50.00														
2211.507	AGGREGATE BASE (CV) CLASS 5	CU YD	\$42.00	2033.00	\$85,386.00	1630	1630	\$68,460.00				881	881	\$37,002.00	337	370	\$15,540.00
2221.509	SHOULDER BASE AGGREGATE CLASS 5 MOD	TON	\$44.50														
2232.504	MILL BITUMINOUS SURFACE (2.0")	SQ YD	\$1.80														
2355.506	BITUMINOUS MATERIAL FOR FOG SEAL	GALLON	\$6.00														
2357.506	BITUMINOUS MATERIAL FOR TACK COAT	GALLON	\$2.50	323.50	\$808.75	403	257.5	\$643.75							122	110	\$275.00

CSAH 30 Improvements - Pay Voucher #8

Item No.	Description	Unit	Unit Price	50% CHISAGO COUNTY SAP 013-630-021 50% CITY OF NORTH BRANCH SAP 225-102-004					SAP 225-591-007 CITY OF NORTH BRANCH			CITY OF NORTH BRANCH					
				NORTH BRANCH TOTAL		ROADWAY			STORM SEWER			SAFE ROUTES TO SCHOOL					
				Contract Quantity	Total Cost	Contract Quantity	Quantity To Date	Amount To Date	Contract Quantity	Quantity To Date	Amount To Date	Contract Quantity	Quantity To Date	Amount To Date	Contract Quantity	Quantity To Date	Amount To Date
2360.509	TYPE SP 12.5 NON WEARING COURSE MIXTURE (3,B)	TON	\$67.00	151.50	\$10,150.50	303	303	\$20,301.00									
2360.509	TYPE SP 12.5 WEARING COURSE MIXTURE (3,C)	TON	\$82.00	672.50	\$55,145.00	605	364.06	\$29,852.92				36			334	386.18	\$31,666.76
2360.509	TYPE SP 12.5 WEARING COURSE MIXTURE (4;F)	TON	\$114.00	238.50	\$27,189.00	477	530.99	\$60,532.86									
2360.509	TYPE SP 12.5 NON WEARING COURSE MIXTURE (4;F)	TON	\$106.00	119.50	\$12,667.00	239	244.38	\$25,904.28									
2411.507	STRUCTURE EXCAVATION CLASS E	CU YD	\$10.00														
2412.502	9X4 PRECAST CONCRETE BOX CULVERT END SECTION	EACH	\$12,000.00														
2412.503	9X4 PRECAST CONCRETE BOX CULVERT	LIN FT	\$1,650.00														
2451.507	GRANULAR BEDDING (CV)	CU YD	\$11.50														
2501.502	18" GS PIPE APRON	EACH	\$300.00														
2501.502	15" RC PIPE APRON	EACH	\$2,700.00														
2501.502	18" RC PIPE APRON	EACH	\$2,900.00														
2501.502	24" RC PIPE APRON	EACH	\$3,200.00														
2501.502	30" RC PIPE APRON	EACH	\$3,400.00	1.00	\$3,400.00				2	2	\$6,800.00						
2501.502	36" RC PIPE APRON	EACH	\$3,800.00														
2501.502	15" RC SAFETY APRON	EACH	\$2,775.00	1.00	\$2,775.00				2	2	\$5,550.00						
2501.502	18" RC SAFETY APRON	EACH	\$2,950.00														
2501.503	18" CAS PIPE CULVERT	LIN FT	\$38.00														
2501.503	18" RC PIPE CULVERT DESIGN 3006 CLASS III	LIN FT	\$46.00	9.00	\$414.00									9	29	\$1,334.00	
2501.503	24" RC PIPE CULVERT DESIGN 3006 CLASS III	LIN FT	\$57.50														
2502.503	4" PERF TP PIPE DRAIN	LIN FT	\$18.00	100.00	\$1,800.00	200	154	\$2,772.00									
2503.503	12" PVC PIPE SEWER	LIN FT	\$54.00	280.00	\$15,120.00									280	302	\$16,308.00	
2503.503	15" RC PIPE SEWER DESIGN 3006 CLASS V	LIN FT	\$38.10	681.50	\$25,965.15				1363	1389	\$52,920.90						
2503.503	18" RC PIPE SEWER DESIGN 3006 CLASS III	LIN FT	\$42.40														
2503.503	24" RC PIPE SEWER DESIGN 3006 CLASS III	LIN FT	\$52.50														
2503.503	30" RC PIPE SEWER DESIGN 3006 CLASS III	LIN FT	\$73.00	235.00	\$17,155.00				470	470	\$34,310.00						
2503.503	36" RC PIPE SEWER DESIGN 3006 CLASS III	LIN FT	\$101.40														
2503.602	CONNECT TO EXISTING MANHOLES (SAN)	EACH	\$4,500.00	1.00	\$4,500.00									1	1	\$4,500.00	
2503.603	20" STEEL CASING PIPE	LIN FT	\$140.00	90.00	\$12,600.00									90	90	\$12,600.00	
2504.602	CONNECT TO EXISTING WATER MAIN	EACH	\$4,000.00	4.00	\$16,000.00									4	4	\$16,000.00	
2504.602	HYDRANT	EACH	\$7,600.00	4.00	\$30,400.00									4	5	\$38,000.00	
2504.602	ADJUST HYDRANT AND GATE VALVE	EACH	\$1,500.00	1.00	\$1,500.00							1	1	\$1,500.00			
2504.602	ADJUST GATE VALVE AND BOX	EACH	\$500.00	1.00	\$500.00	2											
2504.602	6" GATE VALVE AND BOX	EACH	\$2,884.00	4.00	\$11,536.00									4	4	\$11,536.00	
2504.603	6" WATERMAIN DUCTILE IRON CL 52	LIN FT	\$54.00	44.00	\$2,376.00									44	66	\$3,537.00	
2504.603	10" WATERMAIN DUCTILE IRON CL 52	LIN FT	\$84.00	170.00	\$14,280.00									170			
2504.603	16" STEEL CASING PIPE	LIN FT	\$100.00	150.00	\$15,000.00									150	163	\$16,300.00	
2506.502	CASTING ASSEMBLY	EACH	\$1,000.00	11.00	\$11,000.00				18	18	\$18,000.00			2	3	\$3,000.00	
2506.502	ADJUST FRAME AND RING CASTING	EACH	\$950.00	1.00	\$950.00									1	1	\$950.00	
2506.503	CONSTRUCT DRAINAGE STRUCTURE DESIGN G	LIN FT	\$960.00	6.10	\$5,856.00				12.2	12.2	\$11,712.00						
2506.503	CONSTRUCT DRAINAGE STRUCTURE DESIGN 48-4020	LIN FT	\$705.00	44.20	\$31,161.00				88.4	88.4	\$62,322.00						
2506.503	CONSTRUCT DRAINAGE STRUCTURE DESIGN 60-4020	LIN FT	\$600.00	5.45	\$3,270.00				10.9	10.9	\$6,540.00						
2506.602	ADJUST FRAME AND RING CASTING (SPECIAL)	EACH	\$650.00	0.50	\$325.00	1	1	\$650.00									
2506.603	CONSTRUCT DRAINAGE STRUCTURE DESIGN SPECIAL	LIN FT	\$600.00	10.50	\$6,300.00									10.5	12.8	\$7,680.00	
2506.603	RECONSTRUCT DRAINAGE STRUCTURE SPECIAL	LIN FT	\$516.00	6.20	\$3,199.20									6.2	10.7	\$5,521.20	
2511.504	GEOTEXTILE FILTER TYPE 7	SQ YD	\$3.80														

CSAH 30 Improvements - Pay Voucher #8

Item No.	Description	Unit	Unit Price	50% CHISAGO COUNTY SAP 013-630-021 50% CITY OF NORTH BRANCH SAP 225-102-004					SAP 225-591-007 CITY OF NORTH BRANCH			CITY OF NORTH BRANCH					
				NORTH BRANCH TOTAL		ROADWAY			STORM SEWER			SAFE ROUTES TO SCHOOL					
				Contract Quantity	Total Cost	Contract Quantity	Quantity To Date	Amount To Date	Contract Quantity	Quantity To Date	Amount To Date	Contract Quantity	Quantity To Date	Amount To Date	Contract Quantity	Quantity To Date	Amount To Date
2511.507	RANDOM RIPRAP CLASS I	CU YD	\$125.00														
2511.507	RANDOM RIPRAP CLASS II	CU YD	\$125.00	4.10	\$512.50				8.2	10.8	\$1,350.00						
2511.507	RANDOM RIPRAP CLASS III	CU YD	\$120.00														
2521.518	4" CONCRETE WALK	SQ FT	\$5.79	11461.00	\$66,359.19	14310	14185.30	\$82,132.88				3546	3564.30	\$20,637.30	760	858	\$4,967.82
2521.518	7" CONCRETE WALK	SQ FT	\$13.35	1762.50	\$23,529.38	3525	3531	\$47,138.85									
2521.518	3" BITUMINOUS WALK	SQ FT	\$1.75	43632.00	\$76,356.00	11408	13140	\$22,995.00				37928	37223	\$65,140.25			
2521.602	DRILL AND GROUT REINF BAR (EPOXY COATED)	EACH	\$8.50	76.50	\$650.25	33	33	\$280.50				60	76	\$646.00			
2521.618	CONCRETE CURB RAMP WALK	SQ FT	\$9.50	3111.50	\$29,559.25	1619	473.9	\$4,502.05				2302	2919.5	\$27,735.25			
2531.503	CONCRETE CURB AND GUTTER DESIGN B612	LIN FT	\$24.50	107.00	\$2,621.50										107	385	\$9,432.50
2531.503	CONCRETE CURB AND GUTTER DESIGN B624	LIN FT	\$20.25	745.00	\$15,086.25	286	61	\$1,235.25				32	91	\$1,842.75	570	570	\$11,542.50
2531.503	CONCRETE CURB AND GUTTER DESIGN R424	LIN FT	\$26.50	187.00	\$4,955.50	374	374	\$9,911.00									
2531.503	CONCRETE CURB AND GUTTER DESIGN S524	LIN FT	\$22.75	1843.50	\$41,939.63	3687	3841	\$87,382.75									
2531.504	6" CONCRETE DRIVEWAY PAVEMENT	SQ YD	\$71.00														
2531.504	8" CONCRETE DRIVEWAY PAVEMENT	SQ YD	\$84.00	125.00	\$10,500.00										125	544.3	\$45,721.20
2531.618	TRUNCATED DOMES	SQ FT	\$50.00	500.00	\$25,000.00	160	76	\$3,800.00				420	535	\$26,750.00			
2540.602	INSTALL MAIL BOX SUPPORT	EACH	\$275.00	5.00	\$1,375.00	2	2	\$550.00							4	4	\$1,100.00
2545.502	LIGHTING UNIT TYPE 9-30	EACH	\$3,801.18	5.50	\$20,906.49	11	11	\$41,812.98									
2545.502	LIGHT FOUNDATION DESIGN E	EACH	\$1,052.09	0.50	\$526.05	1	1	\$1,052.09									
2545.502	LIGHT FOUNDATION DESIGN STEEL E	EACH	\$1,440.28	5.50	\$7,921.54	11	11.00	\$15,843.08									
2545.502	SERVICE CABINET -TYPE L1	EACH	\$9,718.81	0.50	\$4,859.41	1	1	\$9,718.81									
2545.502	SERVICE EQUIPMENT	EACH	\$1,326.23	0.50	\$663.12	1	1	\$1,326.23									
2545.502	EQUIPMENT PAD B	EACH	\$1,140.75	0.50	\$570.38	1	1	\$1,140.75									
2545.503	2" NON-METALLIC CONDUIT	LIN FT	\$4.79	750.00	\$3,592.50	1500	1560	\$7,472.40									
2545.503	UNDERGROUND WIRE 1/C 8 AWG	LIN FT	\$1.14	3250.00	\$3,705.00	6500	6604	\$7,528.56									
2545.602	INSTALL LIGHTING UNIT	EACH	\$1,123.50	0.50	\$561.75	1											
2554.502	GUIDE POST TYPE B	EACH	\$85.00	2.00	\$170.00				4	4	\$340.00						
2557.503	WIRE FENCE DESIGN 48V-9322	LIN FT	\$80.00														
2563.601	TRAFFIC CONTROL	LUMP SUM	\$34,000.00	0.19	\$6,290.00	0.13	0.13	\$4,420.00	0.04	0.04	\$1,360.00	0.05	0.05	\$1,700.00	0.05	0.05	\$1,700.00
2563.613	PORTABLE CHANGEABLE MESSAGE SIGN	UNIT DAY	\$75.00														
2563.618	CONSTRUCTION SIGN SPECIAL	SQ FT	\$200.00														
2564.602	INSTALL SIGN	EACH	\$450.00														
2564.602	INSTALL SIGN SPECIAL	EACH	\$250.00														
2564.602	INSTALL SIGN PANEL SPECIAL	EACH	\$250.00														
2564.602	DELINEATOR / MARKER	EACH	\$350.00	1.00	\$350.00	2	2	\$700.00									
2564.602	DELINEATOR / MARKER PANEL	EACH	\$95.00	5.00	\$475.00	4	4	\$380.00							3	3	\$285.00
2564.618	SIGN	SQ FT	\$73.50	154.50	\$11,355.75	173	173	\$12,715.50							68	68	\$4,998.00
2565.602	RIGID PVC LOOP DETECTOR 6'X6'	EACH	\$1,097.52														
2565.616	PEDESTRIAN CROSSWALK FLASHER SYSTEM	SYSTEM	\$26,666.16	1.50	\$39,999.24	1	1	\$26,666.16							1	1	\$26,666.16
2573.501	STABILIZED CONSTRUCTION EXIT	LUMP SUM	\$1,500.00														
2573.501	EROSION CONTROL SUPERVISOR	LUMP SUM	\$765.34														
2573.502	STORM DRAIN INLET PROTECTION	EACH	\$200.00	12.00	\$2,400.00	16	16	\$3,200.00							4	5	\$1,000.00
2573.502	CULVERT END CONTROLS	EACH	\$220.00	8.00	\$1,760.00							8	7	\$1,540.00			

CSAH 30 Improvements - Pay Voucher #8

Item No.	Description	Unit	Unit Price	50% CHISAGO COUNTY SAP 013-630-021 50% CITY OF NORTH BRANCH SAP 225-102-004					SAP 225-591-007 CITY OF NORTH BRANCH			CITY OF NORTH BRANCH					
				NORTH BRANCH TOTAL		ROADWAY			STORM SEWER			SAFE ROUTES TO SCHOOL					
				Contract Quantity	Total Cost	Contract Quantity	Quantity To Date	Amount To Date	Contract Quantity	Quantity To Date	Amount To Date	Contract Quantity	Quantity To Date	Amount To Date	Contract Quantity	Quantity To Date	Amount To Date
2573.503	SILT FENCE, TYPE MS	LIN FT	\$1.95	1126.00	\$2,195.70	474	405	\$789.75				889	950	\$1,852.50			
2573.503	SEDIMENT CONTROL LOG TYPE STRAW	LIN FT	\$2.35	1235.50	\$2,903.43	729	764	\$1,795.40				597	656	\$1,541.60	274	420	\$987.00
2573.602	TEMPORARY STREAM DIVERSION SYSTEM	EACH	\$10,000.00														
2574.508	FERTILIZER TYPE 3	POUND	\$0.74	783.50	\$579.79	549	555	\$410.70				404	375	\$277.50	105	15	\$11.10
2575.504	RAPID STABILIZATION METHOD 4	SQ YD	\$1.70	6686.00	\$11,366.20							5450	1920	\$3,264.00	1236	1215	\$2,065.50
2575.505	SEEDING	ACRE	\$525.00	3.35	\$1,758.75	1.9	1.7	\$892.50				1.8	1.71	\$897.75	0.6	0.5	\$262.50
2575.505	DISK ANCHORING	ACRE	\$175.00	1.25	\$218.75	1.5	1.0	\$175.00							0.5	0.6	\$105.00
2575.508	HYDRAULIC STABILIZED FIBER MATRI	POUND	\$0.91	4183.00	\$3,806.53	1306	3500	\$3,185.00				3420	5050	\$4,595.50	110	125	\$113.75
2575.509	MULCH MATERIAL TYPE 3	TON	\$650.00	1.60	\$1,040.00	2.2	1.6	\$1,040.00							0.5	0.5	\$325.00
2575.523	RAPID STABILIZATION METHOD 3	M GALLON	\$495.00	10.00	\$4,950.00	3	2	\$990.00				8	4	\$1,980.00	0.5		
2575.608	SEED TURFGRASS	POUND	\$3.45	286.50	\$988.43	89	20	\$69.00				234	215	\$741.75	8	6.5014	\$22.43
2575.608	SEED MESIC INSLOPE	POUND	\$10.30	154.50	\$1,591.35	105	165	\$1,699.50				80	11	\$113.30	22	25	\$257.50
2582.503	4" SOLID LINE PAINT	LIN FT	\$0.13														
2582.503	6" SOLID LINE PAINT	LIN FT	\$0.17														
2582.503	24" SOLID LINE PAINT	LIN FT	\$3.70	42.00	\$155.40										42	45	\$166.50
2582.503	4" BROKEN LINE PAINT	LIN FT	\$0.13														
2582.503	6" DOTTED LINE PAINT	LIN FT	\$0.17														
2582.503	10" DOTTED LINE PAINT	LIN FT	\$0.40														
2582.503	4" DOUBLE SOLID LINE PAINT	LIN FT	\$0.26	776.00	\$201.76										776	785	\$204.10
2582.503	4" SOLID LINE PAINT GROUND IN (WR)	LIN FT	\$1.10	1008.50	\$1,109.35	1543	921	\$1,013.10							237	139	\$152.90
2582.503	6" SOLID LINE PAINT GROUND IN (WR)	LIN FT	\$1.30	1020.50	\$1,326.65	2041	1086	\$1,411.80									
2582.503	6" DOTTED LINE PAINT GROUND IN (WR)	LIN FT	\$1.30	11.50	\$14.95	23	43	\$55.90									
2582.503	12" DOTTED LINE PREFORM THERMO GROUND IN	LIN FT	\$20.00	64.50	\$1,290.00	43	26	\$520.00							43	25	\$500.00
2582.518	PAVEMENT MESSAGE PAINT	SQ FT	\$4.00	15.50	\$62.00	31	31	\$124.00									
2582.518	CROSSWALK PREFORM THERMOPLASTIC	SQ FT	\$13.00														
2582.518	CROSSWALK PREFORM THERMOPLASTIC GROUND IN	SQ FT	\$15.00	270.00	\$4,050.00	180	180	\$2,700.00							180	180	\$2,700.00
2104.502	REMOVE UTILITY VAULT	EACH	\$300.00									1	1	\$300.00			
2231.507	BITUMINOUS PATCHING MIXTURE	TON	\$150.00									21	25	\$3,750.00			
2504.603	10" WATERMAIN C900	LIN FT	\$76.00												415	446.35	\$33,922.60
2504.602	10" GATE VALVE & BOX	EACH	\$7,370.00												3	3	\$22,110.00
2411.601	REINFORCEMENT BARS	LUMP SUM	\$13,838.00												1	0.4	\$5,535.20
TOTAL					\$1,179,503.14			\$853,417.10			\$219,604.90			\$335,995.45			\$422,808.02

50% Split = \$426,708.55 50% Split = \$109,802.45
 Less 5% Retainage = \$413,907.30 Less 5% Retainage = \$106,508.38 Less 5% Retainage = \$325,915.59 Less 5% Retainage = \$410,123.78
 Total Amount to Date = \$1,256,455.04
 Less Previous Payments = \$1,229,726.53
 Total Due This Pay Voucher = \$26,728.52



JOE TRIPLETT, P.E., DIRECTOR / ENGINEER

To: City of North Branch
 6408 Elm Street
 North Branch, MN 55056

INVOICE

Date: 1/14/2026

Quantity	Description	Price	Amount
	Project: SAP 013-630-021 / CSAH 30		
1	Pay Estimate #8 - RAB Split	23104.90	11,552.45
1	Pay Estimate #8 - SRTS	6719.91	6,719.91
1	Pay Estimate #8 - City Funds	8456.16	8,456.16
			\$ 26,728.52
	Total		\$ 26,728.52

All accounts must be paid within 30 days

Make Check Payable to: Chisago County Finance

**Please Mail to: Chisago County Public Works
 313 North Main Street, Room 400
 Center City, MN 55012**

HD - Blue RTH
01/08/2026
CJH



Chisago County Public Works Department
313 North Main Street, Room 400
Center City, MN 55012
Main: (651) 213-8700

RECEIVED Page 1 of 46
JAN 08 2026

Contract Number: SAP 013-630-021
Pay Request Number: 8
Chisago County Public Works

Project Number	Project Description
SAP 021-030-021	CSAH 30 Improvement Project

Contractor: Knife River Corporation 4787 Shadowwood Dr NE Sauk Rapids, MN 56379	Vendor Number: N/A Up To Date: 12/17/2025
--	--

Contract Amount		Funds Encumbered	
Original Contract	\$6,586,316.60	Original	\$6,586,316.60
Contract Changes	\$216,781.90	Additional	N/A
Revised Contract	\$6,803,098.50	Total	\$6,586,316.60

Work Certified To Date	
Base Bid Items	\$6,538,505.66
Contract Changes	\$213,936.50
Material On Hand	\$0.00
Total	\$6,752,442.16

Work Certified This Request	Work Certified To Date	Less Amount Retained	Less Previous Payments	Amount Paid This Request	Total Amount Paid To Date
\$49,889.04	\$6,752,442.16	\$202,573.26	\$6,367,425.46	\$182,443.44	\$6,549,868.90
Percent: Retained: 3%			Percent Complete: 99.26%		

This is to certify that the items of work shown in this certificate of Pay Estimate have been actually furnished for the work comprising the above-mentioned projects in accordance with the plans and specifications heretofore approved.

Approved By: BEN HOBERT
Signature: Bon Hobert
Chisago County Project Engineer
Date: 1/5/2026

Approved By: Tom Dobrick
Signature: Tom Dobrick
Knife River Corporation Project Manager
Date: 1/5/26

County 13

CHISAGO COUNTY

ACH Remittance Advice Items

Auditor's Warrant Warrant No-306939 01/13/2026 \$182,443.44 WFXX

KNIFE RIVER CORPORATION
PO BOX 1333
ST CLOUD MN 56302-1333

Vendor No. 11081

Description	Invoice Number	Amount

PP#8 SAP013-630-021		182,443.44
Warrant Total.....	\$182,443.44 *	



Chisago County Public Works Department
 313 North Main Street, Room 400
 Center City, MN 55012
 Main: (651) 213-8700

Payment Summary				
No.	Up To Date	Work Certified Per Request	Amount Retained Per Request	Amount Paid Per Request
1	2025-05-02	\$186,687.57	\$9,334.38	\$177,353.19
2	2025-06-02	\$923,670.16	\$46,183.51	\$877,486.65
3	2025-06-30	\$456,533.12	\$22,826.65	\$433,706.47
4	2025-08-01	\$1,063,975.97	\$53,198.80	\$1,010,777.17
5	2025-08-29	\$1,298,418.35	\$64,920.92	\$1,233,497.43
6	2025-09-26	\$1,812,204.21	\$90,610.21	\$1,721,594.00
7	2025-10-27	\$961,063.74	\$48,053.19	\$913,010.55
8	2025-12-17	\$49,889.04	(\$132,554.40)	\$182,443.44

Funding Category Name	Funding Category Number	Work Certified to Date	Less Amount Retained	Less Previous Payments	Amount Paid this Request	Total Amount Paid to Date
Reconditioning		\$503,919.35	\$15,117.59	\$478,723.38	\$10,078.38	\$488,801.76
Reconstruction		\$3,338,065.82	\$100,141.98	\$3,125,412.39	\$112,511.45	\$3,237,923.84
Storm Sewer		\$1,078,631.52	\$32,358.94	\$1,024,699.94	\$21,572.64	\$1,046,272.58
Roadway		\$853,417.10	\$25,602.51	\$809,101.79	\$18,712.80	\$827,814.59
Storm Sewer		\$219,604.90	\$6,588.14	\$208,624.66	\$4,392.10	\$213,016.76
3 - SRTS		\$335,995.45	\$10,079.86	\$319,195.68	\$6,719.91	\$325,915.59
4 - City Local		\$422,808.02	\$12,684.24	\$401,667.62	\$8,456.16	\$410,123.78

Accounting Number	Funding Source	Amount Paid this Request	Revised Contract Amount	Funds Encumbered to Date	Paid Contractor to Date
1 - County Part	Regular (CSAH) (SAAS Act. # 70)	\$144,162.47	\$5,016,571.74	\$4,863,273.04	\$4,772,998.18
2 - RAB Split	Local / Other[1]	\$23,104.90	\$1,094,936.84	\$1,094,936.84	\$1,040,831.35
3 - SRTS	Municipal (MSAS > 5000) (SAAS Act.# 90)	\$6,719.91	\$329,841.50	\$322,475.50	\$325,915.59
4 - City Local Funds	Municipal (MSAS > 5000) (SAAS Act.# 90)	\$8,456.16	\$361,748.42	\$305,631.22	\$410,123.78

Contract Item Status								
Base/Alt	Line	Item	Unit Price	Contract Quantity	Quantity This Request	Amount This Request	Quantity To Date	Amount To Date
Base Bid	1	2021.501/00010 MOBILIZATION (LUMP SUM)	\$460,000.00	1	0	\$0.00	1	\$460,000.00
Base Bid	2	2051.501/00010 MAINT AND RESTORATION OF HAUL ROADS (LUMP SUM)	\$10,500.00	1	0	\$0.00	1	\$10,500.00
Base Bid	3	2101.502/00020 CLEARING (EACH)	\$199.00	51	0	\$0.00	66	\$13,134.00
Base Bid	4	2101.502/00030 GRUBBING (EACH)	\$199.00	51	0	\$0.00	67	\$13,333.00



Chisago County Public Works Department
 313 North Main Street, Room 400
 Center City, MN 55012
 Main: (651) 213-8700

Contract Item Status

Base/Alt	Line	Item	Unit Price	Contract Quantity	Quantity This Request	Amount This Request	Quantity To Date	Amount To Date
Base Bid	5	2101.505/00020 CLEARING (ACRE)	\$2,501.00	0.7	0	\$0.00	0.7	\$1,750.70
Base Bid	6	2101.505/00030 GRUBBING (ACRE)	\$2,501.00	0.7	0	\$0.00	0.7	\$1,750.70
Base Bid	7	2104.502/00090 REMOVE BOX CULVERT (EACH)	\$3,700.00	2	0	\$0.00	2	\$7,400.00
Base Bid	8	2104.502/00100 REMOVE BOX CULVERT END (EACH)	\$3,700.00	4	0	\$0.00	4	\$14,800.00
Base Bid	9	2104.502/00850 REMOVE GATE VALVE AND BOX (EACH)	\$1,800.00	4	0	\$0.00	6	\$10,800.00
Base Bid	10	2104.502/00880 REMOVE HYDRANT (EACH)	\$1,500.00	4	0	\$0.00	4	\$6,000.00
Base Bid	11	2104.502/01185 REMOVE DELINEATOR / MARKER (EACH)	\$175.00	5	0	\$0.00	5	\$875.00
Base Bid	12	2104.502/01220 REMOVE SIGN (EACH)	\$25.00	25	0	\$0.00	30	\$750.00
Base Bid	13	2104.502/01580 REMOVE LIGHT FOUNDATION (EACH)	\$150.00	6	0	\$0.00	6	\$900.00
Base Bid	14	2104.502/02920 SALVAGE LIGHTING UNIT (EACH)	\$635.32	6	0	\$0.00	0	\$0.00
Base Bid	15	2104.502/03300 SALVAGE SIGN (EACH)	\$25.00	5	0	\$0.00	11	\$275.00
Base Bid	16	2104.502/03590 SALVAGE MAIL BOX SUPPORT (EACH)	\$200.00	14	0	\$0.00	14	\$2,800.00



Chisago County Public Works Department
 313 North Main Street, Room 400
 Center City, MN 55012
 Main: (651) 213-8700

Contract Item Status

Base/Alt	Line	Item	Unit Price	Contract Quantity	Quantity This Request	Amount This Request	Quantity To Date	Amount To Date
Base Bid	17	2104.503/00195 SAWING CONCRETE PAVEMENT (FULL DEPTH) (LIN FT)	\$6.00	695	0	\$0.00	754	\$4,524.00
Base Bid	18	2104.503/00205 SAWING BITUMINOUS PAVEMENT (FULL DEPTH) (LIN FT)	\$1.90	758	0	\$0.00	1648	\$3,131.20
Base Bid	19	2104.503/00255 REMOVE PIPE CULVERTS (LIN FT)	\$17.00	914	0	\$0.00	715	\$12,155.00
Base Bid	20	2104.503/00270 REMOVE WATER MAIN (LIN FT)	\$15.00	110	0	\$0.00	142.5	\$2,137.50
Base Bid	21	2104.503/00315 REMOVE CURB AND GUTTER (LIN FT)	\$4.50	1220	0	\$0.00	1522	\$6,849.00
Base Bid	22	2104.503/00460 REMOVE GUARDRAIL-PLATE BEAM (LIN FT)	\$18.00	465	0	\$0.00	465	\$8,370.00
Base Bid	23	2104.503/00820 REMOVE STEEL CASING (LIN FT)	\$10.00	100	0	\$0.00	100	\$1,000.00
Base Bid	24	2104.503/01150 REMOVE TENSION CABLE GUARDRAIL (LIN FT)	\$20.00	505	0	\$0.00	505	\$10,100.00
Base Bid	25	2104.504/00070 REMOVE PAVEMENT (SQ YD)	\$2.00	10531	0	\$0.00	8231.7	\$16,463.40
Base Bid	26	2104.504/00080 REMOVE CONCRETE DRIVEWAY PAVEMENT (SQ YD)	\$2.75	431	0	\$0.00	457.3	\$1,257.58
Base Bid	27	2104.504/00110 REMOVE BITUMINOUS DRIVEWAY PAVEMENT (SQ YD)	\$2.00	710	0	\$0.00	693.9	\$1,387.80
Base Bid	28	2104.504/00120 REMOVE BITUMINOUS PAVEMENT (SQ YD)	\$2.00	35469	0	\$0.00	40476.9	\$80,953.80



Chisago County Public Works Department
 313 North Main Street, Room 400
 Center City, MN 55012
 Main: (651) 213-8700

Contract Item Status								
Base/Alt	Line	Item	Unit Price	Contract Quantity	Quantity This Request	Amount This Request	Quantity To Date	Amount To Date
Base Bid	29	2104.518/00100 REMOVE BITUMINOUS WALK (SQ FT)	\$2.00	10035	0	\$0.00	10200	\$20,400.00
Base Bid	30	2104.518/00140 REMOVE CONCRETE WALK (SQ FT)	\$2.00	970	0	\$0.00	1281	\$2,562.00
Base Bid	31	2104.602/00300 REMOVE SIGN SPECIAL (EACH)	\$25.00	1	0	\$0.00	1	\$25.00
Base Bid	32	2104.602/00400 SALVAGE SIGN SPECIAL (EACH)	\$25.00	7	0	\$0.00	7	\$175.00
Base Bid	33	2104.602/00500 SALVAGE SIGN PANEL SPECIAL (EACH)	\$25.00	3	0	\$0.00	3	\$75.00
Base Bid	34	2106.507 EXCAVATION - COMMON (P) (CU YD)	\$6.00	22163	0	\$0.00	22163	\$132,978.00
Base Bid	35	2106.507 EXCAVATION - SUBGRADE (P) (CU YD)	\$8.50	21120	0	\$0.00	21120	\$179,520.00
Base Bid	36	2106.507 SELECT GRANULAR EMBANKMENT (CV) (P) (CU YD)	\$11.50	24653	0	\$0.00	24653	\$283,509.50
Base Bid	37	2106.507 SELECT GRANULAR EMBANKMENT MOD 10% (CV) (P) (CU YD)	\$11.50	1022	0	\$0.00	0	\$0.00
Base Bid	38	2106.507 COMMON EMBANKMENT (CV) (P) (CU YD)	\$8.00	13126	0	\$0.00	13126	\$105,008.00
Base Bid	39	2106.601/00015 DEWATERING (LUMP SUM)	\$42,000.00	1	0	\$0.00	1	\$42,000.00
Base Bid	40	2130.523/00010 WATER (M GALLON)	\$50.00	400	0	\$0.00	90.8	\$4,540.00



Chisago County Public Works Department
 313 North Main Street, Room 400
 Center City, MN 55012
 Main: (651) 213-8700

Contract Item Status

Base/Alt	Line	Item	Unit Price	Contract Quantity	Quantity This Request	Amount This Request	Quantity To Date	Amount To Date
Base Bid	41	2211.507 AGGREGATE BASE (CV) CLASS 5 (P) (CU YD)	\$42.00	12301	0	\$0.00	12301	\$516,642.00
Base Bid	42	2221.509/00090 SHOULDER BASE AGGREGATE CLASS 5 MOD (TON)	\$44.50	494	0	\$0.00	493.39	\$21,955.86
Base Bid	43	2232.504/00060 MILL BITUMINOUS SURFACE (2.0") (SQ YD)	\$1.80	40837	0	\$0.00	40917.5	\$73,651.50
Base Bid	44	2355.506/00010 BITUMINOUS MATERIAL FOR FOG SEAL (GALLON)	\$6.00	2163	0	\$0.00	2168	\$13,008.00
Base Bid	45	2357.506/00010 BITUMINOUS MATERIAL FOR TACK COAT (GALLON)	\$2.50	11170	0	\$0.00	8547.5	\$21,368.75
Base Bid	46	2360.509/23205 TYPE SP 12.5 NON WEARING COURSE MIXTURE (3,B) (TON)	\$67.00	5102	0	\$0.00	5290.17	\$354,441.39
Base Bid	47	2360.509/23300 TYPE SP 12.5 WEARING COURSE MIXTURE (3,C) (TON)	\$82.00	17081	0	\$0.00	16695.96	\$1,369,068.72
Base Bid	48	2360.509/24600 TYPE SP 12.5 WEARING COURSE MIXTURE (4;F) (TON)	\$114.00	477	0	\$0.00	530.99	\$60,532.86
Base Bid	49	2360.509/24605 TYPE SP 12.5 NON WEARING COURSE MIXTURE (4;F) (TON)	\$106.00	239	0	\$0.00	244.38	\$25,904.28
Base Bid	50	2411.507/04000 STRUCTURE EXCAVATION CLASS E (CU YD)	\$10.00	2743	0	\$0.00	2743	\$27,430.00
Base Bid	51	2412.502/09050 9X4 PRECAST CONCRETE BOX CULVERT END SECTION (EACH)	\$12,000.00	2	0	\$0.00	2	\$24,000.00



Chisago County Public Works Department
 313 North Main Street, Room 400
 Center City, MN 55012
 Main: (651) 213-8700

Contract Item Status

Base/Alt	Line	Item	Unit Price	Contract Quantity	Quantity This Request	Amount This Request	Quantity To Date	Amount To Date
Base Bid	52	2412.503/09040 9X4 PRECAST CONCRETE BOX CULVERT (LIN FT)	\$1,650.00	200	0	\$0.00	200	\$330,000.00
Base Bid	53	2451.507/00150 GRANULAR BEDDING (CV) (CU YD)	\$11.50	183	0	\$0.00	0	\$0.00
Base Bid	54	2501.502/04018 18" GS PIPE APRON (EACH)	\$300.00	14	0	\$0.00	12	\$3,600.00
Base Bid	55	2501.502/05015 15" RC PIPE APRON (EACH)	\$2,700.00	2	0	\$0.00	2	\$5,400.00
Base Bid	56	2501.502/05018 18" RC PIPE APRON (EACH)	\$2,900.00	8	0	\$0.00	8	\$23,200.00
Base Bid	57	2501.502/05024 24" RC PIPE APRON (EACH)	\$3,200.00	6	0	\$0.00	6	\$19,200.00
Base Bid	58	2501.502/05030 30" RC PIPE APRON (EACH)	\$3,400.00	3	0	\$0.00	3	\$10,200.00
Base Bid	59	2501.502/05036 36" RC PIPE APRON (EACH)	\$3,800.00	1	0	\$0.00	1	\$3,800.00
Base Bid	60	2501.502/44015 15" RC SAFETY APRON (EACH)	\$2,775.00	2	0	\$0.00	2	\$5,550.00
Base Bid	61	2501.502/44018 18" RC SAFETY APRON (EACH)	\$2,950.00	2	0	\$0.00	2	\$5,900.00
Base Bid	62	2501.503/00018 18" CAS PIPE CULVERT (LIN FT)	\$38.00	320	0	\$0.00	261	\$9,918.00
Base Bid	63	2501.503/24183 18" RC PIPE CULVERT DESIGN 3006 CLASS III (LIN FT)	\$46.00	396	0	\$0.00	388	\$17,848.00



Chisago County Public Works Department
 313 North Main Street, Room 400
 Center City, MN 55012
 Main: (651) 213-8700

Contract Item Status								
Base/Alt	Line	Item	Unit Price	Contract Quantity	Quantity This Request	Amount This Request	Quantity To Date	Amount To Date
Base Bid	64	2501.503/24243 24" RC PIPE CULVERT DESIGN 3006 CLASS III (LIN FT)	\$57.50	300	0	\$0.00	268	\$15,410.00
Base Bid	65	2502.503/10040 4" PERF TP PIPE DRAIN (LIN FT)	\$18.00	600	0	\$0.00	605	\$10,890.00
Base Bid	66	2503.503/13120 12" PVC PIPE SEWER (LIN FT)	\$54.00	302	0	\$0.00	302	\$16,308.00
Base Bid	67	2503.503/19155 15" RC PIPE SEWER DESIGN 3006 CLASS V (LIN FT)	\$38.10	3307	0	\$0.00	3327	\$126,758.70
Base Bid	68	2503.503/19183 18" RC PIPE SEWER DESIGN 3006 CLASS III (LIN FT)	\$42.40	1012	0	\$0.00	1012	\$42,908.80
Base Bid	69	2503.503/19243 24" RC PIPE SEWER DESIGN 3006 CLASS III (LIN FT)	\$52.50	2054	0	\$0.00	2054	\$107,835.00
Base Bid	70	2503.503/19303 30" RC PIPE SEWER DESIGN 3006 CLASS III (LIN FT)	\$73.00	947	0	\$0.00	947	\$69,131.00
Base Bid	71	2503.503/19363 36" RC PIPE SEWER DESIGN 3006 CLASS III (LIN FT)	\$101.40	267	0	\$0.00	267	\$27,073.80
Base Bid	72	2503.602/00310 CONNECT TO EXISTING MANHOLES (SAN) (EACH)	\$4,500.00	1	0	\$0.00	1	\$4,500.00
Base Bid	73	2503.603/31200 20" STEEL CASING PIPE (LIN FT)	\$140.00	90	0	\$0.00	90	\$12,600.00
Base Bid	74	2504.602/00010 CONNECT TO EXISTING WATER MAIN (EACH)	\$4,000.00	4	0	\$0.00	4	\$16,000.00
Base Bid	75	2504.602/00020 HYDRANT (EACH)	\$7,600.00	4	0	\$0.00	5	\$38,000.00



Chisago County Public Works Department
 313 North Main Street, Room 400
 Center City, MN 55012
 Main: (651) 213-8700

Contract Item Status

Base/Alt	Line	Item	Unit Price	Contract Quantity	Quantity This Request	Amount This Request	Quantity To Date	Amount To Date
Base Bid	76	2504.602/00026 ADJUST HYDRANT AND GATE VALVE (EACH)	\$1,500.00	1	0	\$0.00	1	\$1,500.00
Base Bid	77	2504.602/00032 ADJUST GATE VALVE AND BOX (EACH)	\$500.00	2	0	\$0.00	0	\$0.00
Base Bid	78	2504.602/00806 6" GATE VALVE AND BOX (EACH)	\$2,884.00	4	0	\$0.00	4	\$11,536.00
Base Bid	79	2504.603/01062 6" WATERMAIN DUCTILE IRON CL 52 (LIN FT)	\$54.00	56	0	\$0.00	65.5	\$3,537.00
Base Bid	80	2504.603/01102 10" WATERMAIN DUCTILE IRON CL 52 (LIN FT)	\$84.00	0	0	\$0.00	0	\$0.00
Base Bid	81	2504.603/04160 16" STEEL CASING PIPE (LIN FT)	\$100.00	164	0	\$0.00	163	\$16,300.00
Base Bid	82	2506.502/06000 CASTING ASSEMBLY (EACH)	\$1,000.00	70	0	\$0.00	69	\$69,000.00
Base Bid	83	2506.502/06020 ADJUST FRAME AND RING CASTING (EACH)	\$950.00	2	0	\$0.00	2	\$1,900.00
Base Bid	84	2506.503/00070 CONSTRUCT DRAINAGE STRUCTURE DESIGN G (LIN FT)	\$960.00	94.2	0	\$0.00	94.2	\$90,432.00
Base Bid	85	2506.503/02420 CONSTRUCT DRAINAGE STRUCTURE DESIGN 48-4020 (LIN FT)	\$705.00	276.7	0	\$0.00	276.7	\$195,073.50
Base Bid	86	2506.503/03020 CONSTRUCT DRAINAGE STRUCTURE DESIGN 60-4020 (LIN FT)	\$600.00	26.9	0	\$0.00	26.9	\$16,140.00
Base Bid	87	2506.602/06450 ADJUST FRAME AND RING CASTING (SPECIAL) (EACH)	\$650.00	2	0	\$0.00	1	\$650.00



Chisago County Public Works Department
 313 North Main Street, Room 400
 Center City, MN 55012
 Main: (651) 213-8700

Contract Item Status								
Base/Alt	Line	Item	Unit Price	Contract Quantity	Quantity This Request	Amount This Request	Quantity To Date	Amount To Date
Base Bid	88	2506.603/30000 CONSTRUCT DRAINAGE STRUCTURE DESIGN SPECIAL (LIN FT)	\$600.00	12.8	0	\$0.00	12.8	\$7,680.00
Base Bid	89	2506.603/50000 RECONSTRUCT DRAINAGE STRUCTURE SPECIAL (LIN FT)	\$516.00	6.2	0	\$0.00	10.7	\$5,521.20
Base Bid	90	2511.504/00017 GEOTEXTILE FILTER TYPE 7 (SQ YD)	\$3.80	398	0	\$0.00	169.9	\$645.62
Base Bid	91	2511.507/00012 RANDOM RIPRAP CLASS I (CU YD)	\$125.00	7	0	\$0.00	9.6	\$1,200.00
Base Bid	92	2511.507/00013 RANDOM RIPRAP CLASS II (CU YD)	\$125.00	62.8	0	\$0.00	51.6	\$6,450.00
Base Bid	93	2511.507/00014 RANDOM RIPRAP CLASS III (CU YD)	\$120.00	400	0	\$0.00	110.4	\$13,248.00
Base Bid	94	2521.518/00040 4" CONCRETE WALK (SQ FT)	\$5.79	19101	0	\$0.00	19405.6	\$112,358.42
Base Bid	95	2521.518/00070 7" CONCRETE WALK (SQ FT)	\$13.35	3525	0	\$0.00	3531	\$47,138.85
Base Bid	96	2521.518/00130 3" BITUMINOUS WALK (SQ FT)	\$1.75	49336	0	\$0.00	50363	\$88,135.25
Base Bid	97	2521.602/00030 DRILL AND GROUT REINF BAR (EPOXY COATED) (EACH)	\$8.50	93	0	\$0.00	109	\$926.50
Base Bid	98	2521.618/00400 CONCRETE CURB RAMP WALK (SQ FT)	\$9.50	4449	0	\$0.00	3508.4	\$33,329.80



Chisago County Public Works Department
 313 North Main Street, Room 400
 Center City, MN 55012
 Main: (651) 213-8700

Contract Item Status								
Base/Alt	Line	Item	Unit Price	Contract Quantity	Quantity This Request	Amount This Request	Quantity To Date	Amount To Date
Base Bid	99	2531.503/02310 CONCRETE CURB AND GUTTER DESIGN B612 (LIN FT)	\$24.50	310	0	\$0.00	659	\$16,145.50
Base Bid	100	2531.503/02320 CONCRETE CURB AND GUTTER DESIGN B624 (LIN FT)	\$20.25	9892	0	\$0.00	10101	\$204,545.25
Base Bid	101	2531.503/18120 CONCRETE CURB AND GUTTER DESIGN R424 (LIN FT)	\$26.50	374	0	\$0.00	374	\$9,911.00
Base Bid	102	2531.503/19220 CONCRETE CURB AND GUTTER DESIGN S524 (LIN FT)	\$22.75	3687	0	\$0.00	3841	\$87,382.75
Base Bid	103	2531.504/00060 6" CONCRETE DRIVEWAY PAVEMENT (SQ YD)	\$71.00	340	0	\$0.00	674.2	\$47,868.20
Base Bid	104	2531.504/00080 8" CONCRETE DRIVEWAY PAVEMENT (SQ YD)	\$84.00	828	0	\$0.00	1002.6	\$84,218.40
Base Bid	105	2531.618/00010 TRUNCATED DOMES (SQ FT)	\$50.00	580	0	\$0.00	611	\$30,550.00
Base Bid	106	2540.602/00140 INSTALL MAIL BOX SUPPORT (EACH)	\$275.00	14	0	\$0.00	14	\$3,850.00
Base Bid	107	2545.502/09030 LIGHTING UNIT TYPE 9-30 (EACH)	\$3,801.18	11	0	\$0.00	11	\$41,812.98
Base Bid	108	2545.502/14080 LIGHT FOUNDATION DESIGN E (EACH)	\$1,052.09	6	0	\$0.00	6	\$6,312.54
Base Bid	109	2545.502/16050 LIGHT FOUNDATION DESIGN STEEL E (EACH)	\$1,440.28	11	0	\$0.00	11	\$15,843.08



Chisago County Public Works Department
 313 North Main Street, Room 400
 Center City, MN 55012
 Main: (651) 213-8700

Contract Item Status

Base/Alt	Line	Item	Unit Price	Contract Quantity	Quantity This Request	Amount This Request	Quantity To Date	Amount To Date
Base Bid	110	2545.502/21201 SERVICE CABINET -TYPE L1 (EACH)	\$9,718.81	1	0	\$0.00	1	\$9,718.81
Base Bid	111	2545.502/22510 SERVICE EQUIPMENT (EACH)	\$1,326.23	1	0	\$0.00	1	\$1,326.23
Base Bid	112	2545.502/22521 EQUIPMENT PAD B (EACH)	\$1,140.75	1	0	\$0.00	1	\$1,140.75
Base Bid	113	2545.503/01053 2" NON-METALLIC CONDUIT (LIN FT)	\$4.79	1500	0	\$0.00	1560	\$7,472.40
Base Bid	114	2545.503/03080 UNDERGROUND WIRE 1/C 8 AWG (LIN FT)	\$1.14	6500	0	\$0.00	6604	\$7,528.56
Base Bid	115	2545.602/23130 INSTALL LIGHTING UNIT (EACH)	\$1,123.50	6	0	\$0.00	0	\$0.00
Base Bid	116	2554.502/00002 GUIDE POST TYPE B (EACH)	\$85.00	21	0	\$0.00	21	\$1,785.00
Base Bid	117	2557.503/01223 WIRE FENCE DESIGN 48V-9322 (LIN FT)	\$80.00	50	0	\$0.00	50	\$4,000.00
Base Bid	118	2563.601/00010 TRAFFIC CONTROL (LUMP SUM)	\$34,000.00	1	0	\$0.00	1	\$34,000.00
Base Bid	119	2563.613/01100 PORTABLE CHANGEABLE MESSAGE SIGN (UNIT DAY)	\$75.00	100	0	\$0.00	93	\$6,975.00
Base Bid	120	2563.618/00100 CONSTRUCTION SIGN SPECIAL (SQ FT)	\$200.00	7	0	\$0.00	10	\$2,000.00
Base Bid	121	2564.602/01515 INSTALL SIGN (EACH)	\$450.00	5	0	\$0.00	12	\$5,400.00



Chisago County Public Works Department
 313 North Main Street, Room 400
 Center City, MN 55012
 Main: (651) 213-8700

Contract Item Status

Base/Alt	Line	Item	Unit Price	Contract Quantity	Quantity This Request	Amount This Request	Quantity To Date	Amount To Date
Base Bid	122	2564.602/01516 INSTALL SIGN SPECIAL (EACH)	\$250.00	7	0	\$0.00	7	\$1,750.00
Base Bid	123	2564.602/01519 INSTALL SIGN PANEL SPECIAL (EACH)	\$250.00	3	0	\$0.00	3	\$750.00
Base Bid	124	2564.602/02340 DELINEATOR / MARKER (EACH)	\$350.00	3	0	\$0.00	3	\$1,050.00
Base Bid	125	2564.602/02350 DELINEATOR / MARKER PANEL (EACH)	\$95.00	13	0	\$0.00	13	\$1,235.00
Base Bid	126	2564.618/00010 SIGN (SQ FT)	\$73.50	682	0	\$0.00	682	\$50,127.00
Base Bid	127	2565.602/51717 RIGID PVC LOOP DETECTOR 6'X6' (EACH)	\$1,097.52	9	0	\$0.00	11	\$12,072.72
Base Bid	128	2565.616/00060 PEDESTRIAN CROSSWALK FLASHER SYSTEM (SYSTEM)	\$26,666.16	3	0	\$0.00	3	\$79,998.48
Base Bid	129	2573.501/00025 STABILIZED CONSTRUCTION EXIT (LUMP SUM)	\$1,500.00	1	0	\$0.00	1	\$1,500.00
Base Bid	130	2573.501/00030 EROSION CONTROL SUPERVISOR (LUMP SUM)	\$765.34	1	0	\$0.00	1	\$765.34
Base Bid	131	2573.502/00110 STORM DRAIN INLET PROTECTION (EACH)	\$200.00	78	0	\$0.00	78	\$15,600.00
Base Bid	132	2573.502/00140 CULVERT END CONTROLS (EACH)	\$220.00	17	0	\$0.00	14	\$3,080.00
Base Bid	133	2573.503/00023 SILT FENCE, TYPE MS (LIN FT)	\$1.95	8278	0	\$0.00	8381	\$16,342.95



Chisago County Public Works Department
 313 North Main Street, Room 400
 Center City, MN 55012
 Main: (651) 213-8700

Contract Item Status								
Base/Alt	Line	Item	Unit Price	Contract Quantity	Quantity This Request	Amount This Request	Quantity To Date	Amount To Date
Base Bid	134	2573.503/00060 SEDIMENT CONTROL LOG TYPE STRAW (LIN FT)	\$2.35	3678	0	\$0.00	3710	\$8,718.50
Base Bid	135	2573.602/00030 TEMPORARY STREAM DIVERSION SYSTEM (EACH)	\$10,000.00	1	0	\$0.00	0	\$0.00
Base Bid	136	2574.508/00013 FERTILIZER TYPE 3 (POUND)	\$0.74	3378	150	\$111.00	3450	\$2,553.00
Base Bid	137	2575.504/00110 RAPID STABILIZATION METHOD 4 (SQ YD)	\$1.70	31170	0	\$0.00	7184	\$12,212.80
Base Bid	138	2575.505/00021 SEEDING (ACRE)	\$525.00	12.3	0.5	\$262.50	11.91	\$6,252.75
Base Bid	139	2575.505/00025 DISK ANCHORING (ACRE)	\$175.00	8.4	0	\$0.00	5.7	\$997.50
Base Bid	140	2575.508/40006 HYDRAULIC STABILIZED FIBER MATRIX (POUND)	\$0.91	9445	850	\$773.50	13425	\$12,216.75
Base Bid	141	2575.509/00030 MULCH MATERIAL TYPE 3 (TON)	\$650.00	12.4	0	\$0.00	11.45	\$7,442.50
Base Bid	142	2575.523/00020 RAPID STABILIZATION METHOD 3 (M GALLON)	\$495.00	22	0	\$0.00	12	\$5,940.00
Base Bid	143	2575.608/25080 SEED TURFGRASS (POUND)	\$3.45	645	20	\$69.00	545	\$1,880.25
Base Bid	144	2575.608/25100 SEED MESIC INSLOPE (POUND)	\$10.30	648	50	\$515.00	604	\$6,221.20
Base Bid	145	2582.503/10104 4" SOLID LINE PAINT (LIN FT)	\$0.13	9597	0	\$0.00	9599	\$1,247.87
Base Bid	146	2582.503/10106 6" SOLID LINE PAINT (LIN FT)	\$0.17	44609	0	\$0.00	45274	\$7,696.58



Chisago County Public Works Department
 313 North Main Street, Room 400
 Center City, MN 55012
 Main: (651) 213-8700

Contract Item Status

Base/Alt	Line	Item	Unit Price	Contract Quantity	Quantity This Request	Amount This Request	Quantity To Date	Amount To Date
Base Bid	147	2582.503/10124 24" SOLID LINE PAINT (LIN FT)	\$3.70	545	0	\$0.00	645	\$2,386.50
Base Bid	148	2582.503/10204 4" BROKEN LINE PAINT (LIN FT)	\$0.13	3950	0	\$0.00	3890	\$505.70
Base Bid	149	2582.503/10306 6" DOTTED LINE PAINT (LIN FT)	\$0.17	37	0	\$0.00	30	\$5.10
Base Bid	150	2582.503/10310 10" DOTTED LINE PAINT (LIN FT)	\$0.40	88	0	\$0.00	96	\$38.40
Base Bid	151	2582.503/10404 4" DOUBLE SOLID LINE PAINT (LIN FT)	\$0.26	6680	0	\$0.00	6424	\$1,670.24
Base Bid	152	2582.503/20104 4" SOLID LINE PAINT GROUND IN (WR) (LIN FT)	\$1.10	2869	0	\$0.00	1738	\$1,911.80
Base Bid	153	2582.503/20106 6" SOLID LINE PAINT GROUND IN (WR) (LIN FT)	\$1.30	3856	0	\$0.00	2049	\$2,663.70
Base Bid	154	2582.503/20306 6" DOTTED LINE PAINT GROUND IN (WR) (LIN FT)	\$1.30	46	0	\$0.00	86	\$111.80
Base Bid	155	2582.503/76312 12" DOTTED LINE PREFORM THERMO GROUND IN (LIN FT)	\$20.00	86	0	\$0.00	51	\$1,020.00
Base Bid	156	2582.518/01000 PAVEMENT MESSAGE PAINT (SQ FT)	\$4.00	1105	0	\$0.00	1096.95	\$4,387.80
Base Bid	157	2582.518/08000 CROSSWALK PREFORM THERMOPLASTIC (SQ FT)	\$13.00	474	0	\$0.00	1080	\$14,040.00



Chisago County Public Works Department
 313 North Main Street, Room 400
 Center City, MN 55012
 Main: (651) 213-8700

Contract Item Status								
Base/Alt	Line	Item	Unit Price	Contract Quantity	Quantity This Request	Amount This Request	Quantity To Date	Amount To Date
Base Bid	158	2582.518/08020 CROSSWALK PREFORM THERMOPLASTIC GROUND IN (SQ FT)	\$15.00	360	0	\$0.00	360	\$5,400.00
Base Bid Totals:						\$1,731.00		\$6,538,505.66

Project Category Totals			
Project	Category	Amount This Request	Amount To Date
SAP 021-030-021		\$1,731.00	\$6,538,505.66

Contract Change Item Status											
Project	CC	Line	Item	Unit Price	Contract Quantity	Contract Amount	New Item or Adj to Existing	Quantity This Request	Amount This Request	Quantity To Date	Amount To Date
SAP 021-030-021	CO1	66	2503.503/13120 12" PVC PIPE SEWER (LIN FT)	\$54.00	22	\$1,188.00	ADJ				
SAP 021-030-021	CO1	79	2504.603/01062 6" WATERMAIN DUCTILE IRON CL 52 (LIN FT)	\$54.00	12	\$648.00	ADJ				
SAP 021-030-021	CO1	80	2504.603/01102 10" WATERMAIN DUCTILE IRON CL 52 (LIN FT)	\$84.00	-170	(\$14,280.00)	ADJ				
SAP 021-030-021	CO1	81	2504.603/04160 16" STEEL CASING PIPE (LIN FT)	\$100.00	14	\$1,400.00	ADJ				
SAP 021-030-021	CO1	88	2506.603/30000 CONSTRUCT DRAINAGE STRUCTURE DESIGN SPECIAL (LIN FT)	\$600.00	2.3	\$1,380.00	ADJ				
SAP 021-030-021	CO1	159	2504.603 10" WATERMAIN C900 (LIN FT)	\$76.00	415	\$31,540.00	ITM	0	\$0.00	446.35	\$33,922.60
SAP 021-030-021	CO1	160	2504.602 10" GATE VALVE & BOX (EACH)	\$7,370.00	1	\$7,370.00	ITM	0	\$0.00	3	\$22,110.00
SAP 021-030-021	CO2	162	2104.502 REMOVE UTILITY VAULT (EACH)	\$300.00	1	\$300.00	ITM	0	\$0.00	1	\$300.00
SAP 021-030-021	CO3	34	2106.507 EXCAVATION - COMMON (P) (CU YD)	\$6.00	78	\$468.00	ADJ				
SAP 021-030-021	CO3	38	2106.507 COMMON EMBANKMENT (CV) (P) (CU YD)	\$8.00	11	\$88.00	ADJ				
SAP 021-030-021	CO3	41	2211.507 AGGREGATE BASE (CV) CLASS 5 (P) (CU YD)	\$42.00	80	\$3,360.00	ADJ				
SAP 021-030-021	CO3	163	2231.507 BITUMINOUS PATCHING MIXTURE (TON)	\$150.00	21	\$3,150.00	ITM	0	\$0.00	25	\$3,750.00



Chisago County Public Works Department
 313 North Main Street, Room 400
 Center City, MN 55012
 Main: (651) 213-8700

Contract Change Item Status											
Project	CC	Line	Item	Unit Price	Contract Quantity	Contract Amount	New Item or Adj to Existing	Quantity This Request	Amount This Request	Quantity To Date	Amount To Date
SAP 021-030-021	CO4	21	2104.503/00315 REMOVE CURB AND GUTTER (LIN FT)	\$4.50	100	\$450.00	ADJ				
SAP 021-030-021	CO4	34	2106.507 EXCAVATION - COMMON (P) (CU YD)	\$6.00	80	\$480.00	ADJ				
SAP 021-030-021	CO4	38	2106.507 COMMON EMBANKMENT (CV) (P) (CU YD)	\$8.00	40	\$320.00	ADJ				
SAP 021-030-021	CO4	41	2211.507 AGGREGATE BASE (CV) CLASS 5 (P) (CU YD)	\$42.00	33	\$1,386.00	ADJ				
SAP 021-030-021	CO4	63	2501.503/24183 18" RC PIPE CULVERT DESIGN 3006 CLASS III (LIN FT)	\$46.00	20	\$920.00	ADJ				
SAP 021-030-021	CO4	99	2531.503/02310 CONCRETE CURB AND GUTTER DESIGN B612 (LIN FT)	\$24.50	40	\$980.00	ADJ				
SAP 021-030-021	CO4	104	2531.504/00080 8" CONCRETE DRIVEWAY PAVEMENT (SQ YD)	\$84.00	200	\$16,800.00	ADJ				
SAP 021-030-021	CO5	164	2411.601 REINFORCEMENT BARS (LS)	\$13,838.00	1	\$13,838.00	ITM	0	\$0.00	1	\$13,838.00
SAP 021-030-021	CO7	35	2106.507 EXCAVATION - SUBGRADE (P) (CU YD)	\$8.50	249	\$2,116.50	ADJ				
SAP 021-030-021	CO7	36	2106.507 SELECT GRANULAR EMBANKMENT (CV) (P) (CU YD)	\$11.50	249	\$2,863.50	ADJ				
SAP 021-030-021	CO8	165	2104.504 REMOVE BITUMINOUS PAVEMENT - OAK TO TH 95 (SQ YD)	\$5.50	4209.4	\$23,151.70	ITM	0	\$0.00	4209.4	\$23,151.70
SAP 021-030-021	CO8	166	2360.509 TYPE SP 12.5 NON WEARING COURSE MIXTURE (3,B) - OAK TO TH 95 (TON)	\$82.00	837.88	\$68,706.16	ITM	0	\$0.00	837.88	\$68,706.16
SAP 021-030-021	CO9	167	2360.601 BITUMINOUS PAVEMENT - DENSITY INCENTIVE (LUMP SUM)	\$46,355.97	1	\$46,355.97	ITM	1	\$46,355.97	1	\$46,355.97
SAP 021-030-021	CO9	168	2360.601 BITUMINOUS PAVEMENT - SMOOTHNESS AND ALR INCENTIVE (LUMP SUM)	\$1,802.07	1	\$1,802.07	ITM	1	\$1,802.07	1	\$1,802.07
Contract Change Totals:									\$48,158.04		\$213,936.50

Contract Change Totals			
Number	Description	Effective Date	Amount
1	The	05/07/2025	\$29,246.00
2	Empty utility vault removal	06/04/2025	\$300.00
3	Oak to Maple Walk Width and Maple Improvements	06/04/2025	\$7,066.00



Chisago County Public Works Department
 313 North Main Street, Room 400
 Center City, MN 55012
 Main: (651) 213-8700

4		08/06/2025	\$21,336.00
5	Add rebar to the Fire Hall's concrete driveway	09/05/2025	\$13,838.00
7	Extra Subgrade Excavation and Select Granular Embankment	09/24/2025	\$4,980.00
8	Full Depth Bituminous Pavement Removal Oak to 95	09/29/2025	\$91,857.86
9	This Change Order is being written to document incentive payments in accordance to the Contract. Standard Specification 2360, "Plant Mixed Asphalt Pavement" require payment of incentive or assessment of disincentives for bituminous pavement and material properties. Standard Specification 2399, "Pavement Surface Smoothness" require payment of incentive or assessment of disincentives for bituminous pavement ride smoothness and areas of localized roughness. The Department has evaluated the bituminous pavement material properties in accordance with the specifications and special provisions and has determined payment of incentive or assessments of disincentives as shown below in the estimate of cost. Documentation supporting these incentives/disincentives are depicted in the attached documents and will remain in the Project Engineer's files. No change to Contract Time.	11/04/2025	\$48,158.04

Material On Hand Additions					
Line	Item	Description	Date	Added	Comments

Material On Hand Balance						
Line	Item	Description	Date	Added	Used	Remaining
109	2545.502/16050	LIGHT FOUNDATION DESIGN STEEL E	2025-08-06	11 EACH \$9,210.55	11 EACH \$9,210.55	0 EACH \$0.00
128	2565.616/00060	PEDESTRIAN CROSSWALK FLASHER SYSTEM	2025-08-06	1 SYSTEM \$17,560.44	1 SYSTEM \$17,560.44	0 SYSTEM \$0.00
128	2565.616/00060	PEDESTRIAN CROSSWALK FLASHER SYSTEM	2025-08-06	1 SYSTEM \$17,560.44	1 SYSTEM \$17,560.44	0 SYSTEM \$0.00

Contract Total	\$6,752,442.16
-----------------------	-----------------------

Contract Item Status by Funding Breakdown								
Funding Cat	Line	Item	Unit Price	Contract Quantity	Quantity This Request	Amount This Request	Quantity To Date	Amount To Date
1 - SAP 013-630-021 / Reconditioning	1	2021.501/00010 MOBILIZATION (LUMP SUM)	\$460,000.00	0.07	0	\$0.00	0.07	\$32,200.00
1 - SAP 013-630-021 / Reconditioning	43	2232.504/00060 MILL BITUMINOUS SURFACE (2.0") (SQ YD)	\$1.80	36863	0	\$0.00	40917.5	\$73,651.50
1 - SAP 013-630-021 / Reconditioning	44	2355.506/00010 BITUMINOUS MATERIAL FOR FOG SEAL (GALLON)	\$6.00	2163	0	\$0.00	2168	\$13,008.00



Contract Item Status by Funding Breakdown

Funding Cat	Line	Item	Unit Price	Contract Quantity	Quantity This Request	Amount This Request	Quantity To Date	Amount To Date
1 - SAP 013-630-021 / Reconditioning	45	2357.508/00010 BITUMINOUS MATERIAL FOR TACK COAT (GALLON)	\$2.50	3326	0	\$0.00	3300	\$8,250.00
1 - SAP 013-630-021 / Reconditioning	47	2360.509/23300 TYPE SP 12.5 WEARING COURSE MIXTURE (3,C) (TON)	\$82.00	4413	0	\$0.00	4500.16	\$369,013.12
1 - SAP 013-630-021 / Reconditioning	118	2563.601/00010 TRAFFIC CONTROL (LUMP SUM)	\$34,000.00	0.07	0	\$0.00	0.07	\$2,380.00
1 - SAP 013-630-021 / Reconditioning	145	2582.503/10104 4" SOLID LINE PAINT (LIN FT)	\$0.13	3065	0	\$0.00	2841	\$369.33
1 - SAP 013-630-021 / Reconditioning	146	2582.503/10106 6" SOLID LINE PAINT (LIN FT)	\$0.17	25698	0	\$0.00	25720	\$4,372.40
1 - SAP 013-630-021 / Reconditioning	148	2582.503/10204 4" BROKEN LINE PAINT (LIN FT)	\$0.13	2610	0	\$0.00	2520	\$327.60
1 - SAP 013-630-021 / Reconditioning	150	2582.503/10310 10" DOTTED LINE PAINT (LIN FT)	\$0.40	88	0	\$0.00	96	\$38.40
1 - SAP 013-630-021 / Reconditioning	156	2582.518/01000 PAVEMENT MESSAGE PAINT (SQ FT)	\$4.00	79	0	\$0.00	77.25	\$309.00
1 - SAP 013-630-021 / Reconstruction	1	2021.501/00010 MOBILIZATION (LUMP SUM)	\$460,000.00	0.48	0	\$0.00	0.48	\$220,800.00
1 - SAP 013-630-021 / Reconstruction	2	2051.501/00010 MAINT AND RESTORATION OF HAUL ROADS (LUMP SUM)	\$10,500.00	1	0	\$0.00	1	\$10,500.00
1 - SAP 013-630-021 /	5	2101.505/00020 CLEARING (ACRE)	\$2,501.00	0.1	0	\$0.00	0.1	\$250.10



Chisago County Public Works Department
 313 North Main Street, Room 400
 Center City, MN 55012
 Main: (651) 213-8700

Contract Item Status by Funding Breakdown

Funding Cat	Line	Item	Unit Price	Contract Quantity	Quantity This Request	Amount This Request	Quantity To Date	Amount To Date
Reconstruction								
1 - SAP 013-630-021 / Reconstruction	6	2101.505/00030 GRUBBING (ACRE)	\$2,501.00	0.1	0	\$0.00	0.1	\$250.10
1 - SAP 013-630-021 / Reconstruction	11	2104.502/01185 REMOVE DELINEATOR / MARKER (EACH)	\$175.00	5	0	\$0.00	5	\$875.00
1 - SAP 013-630-021 / Reconstruction	12	2104.502/01220 REMOVE SIGN (EACH)	\$25.00	22	0	\$0.00	27	\$675.00
1 - SAP 013-630-021 / Reconstruction	13	2104.502/01580 REMOVE LIGHT FOUNDATION (EACH)	\$150.00	5	0	\$0.00	5	\$750.00
1 - SAP 013-630-021 / Reconstruction	14	2104.502/02920 SALVAGE LIGHTING UNIT (EACH)	\$635.32	5	0	\$0.00	0	\$0.00
1 - SAP 013-630-021 / Reconstruction	15	2104.502/03300 SALVAGE SIGN (EACH)	\$25.00	5	0	\$0.00	11	\$275.00
1 - SAP 013-630-021 / Reconstruction	16	2104.502/03590 SALVAGE MAIL BOX SUPPORT (EACH)	\$200.00	8	0	\$0.00	8	\$1,600.00
1 - SAP 013-630-021 / Reconstruction	17	2104.503/00195 SAWING CONCRETE PAVEMENT (FULL DEPTH) (LIN FT)	\$6.00	671	0	\$0.00	730	\$4,380.00
1 - SAP 013-630-021 / Reconstruction	18	2104.503/00205 SAWING BITUMINOUS PAVEMENT (FULL DEPTH) (LIN FT)	\$1.90	648	0	\$0.00	1057	\$2,008.30
1 - SAP 013-630-021 / Reconstruction	19	2104.503/00255 REMOVE PIPE CULVERTS (LIN FT)	\$17.00	806	0	\$0.00	607	\$10,319.00
1 - SAP 013-630-021 / Reconstruction	21	2104.503/00315 REMOVE CURB AND GUTTER (LIN FT)	\$4.50	1002	0	\$0.00	969	\$4,360.50



Chisago County Public Works Department
 313 North Main Street, Room 400
 Center City, MN 55012
 Main: (651) 213-8700

Contract Item Status by Funding Breakdown

Funding Cat	Line	Item	Unit Price	Contract Quantity	Quantity This Request	Amount This Request	Quantity To Date	Amount To Date
1 - SAP 013-630-021 / Reconstruction	22	2104.503/00460 REMOVE GUARDRAIL-PLATE BEAM (LIN FT)	\$18.00	465	0	\$0.00	465	\$8,370.00
1 - SAP 013-630-021 / Reconstruction	24	2104.503/01150 REMOVE TENSION CABLE GUARDRAIL (LIN FT)	\$20.00	505	0	\$0.00	505	\$10,100.00
1 - SAP 013-630-021 / Reconstruction	25	2104.504/00070 REMOVE PAVEMENT (SQ YD)	\$2.00	8185	0	\$0.00	5879.7	\$11,759.40
1 - SAP 013-630-021 / Reconstruction	26	2104.504/00080 REMOVE CONCRETE DRIVEWAY PAVEMENT (SQ YD)	\$2.75	431	0	\$0.00	457.301 8181818	\$1,257.58
1 - SAP 013-630-021 / Reconstruction	27	2104.504/00110 REMOVE BITUMINOUS DRIVEWAY PAVEMENT (SQ YD)	\$2.00	540	0	\$0.00	441	\$882.00
1 - SAP 013-630-021 / Reconstruction	28	2104.504/00120 REMOVE BITUMINOUS PAVEMENT (SQ YD)	\$2.00	32033	0	\$0.00	35962.3	\$71,924.60
1 - SAP 013-630-021 / Reconstruction	30	2104.518/00140 REMOVE CONCRETE WALK (SQ FT)	\$2.00	237	0	\$0.00	290	\$580.00
1 - SAP 013-630-021 / Reconstruction	32	2104.602/00400 SALVAGE SIGN SPECIAL (EACH)	\$25.00	7	0	\$0.00	7	\$175.00
1 - SAP 013-630-021 / Reconstruction	33	2104.602/00500 SALVAGE SIGN PANEL SPECIAL (EACH)	\$25.00	3	0	\$0.00	3	\$75.00
1 - SAP 013-630-021 / Reconstruction	34	2106.507 EXCAVATION - COMMON (P) (CU YD)	\$6.00	13093	0	\$0.00	13093	\$78,558.00
1 - SAP 013-630-021 / Reconstruction	35	2106.507 EXCAVATION - SUBGRADE (P) (CU YD)	\$8.50	16760	0	\$0.00	16760	\$142,460.00



Chisago County Public Works Department
 313 North Main Street, Room 400
 Center City, MN 55012
 Main: (651) 213-8700

Contract Item Status by Funding Breakdown

Funding Cat	Line	Item	Unit Price	Contract Quantity	Quantity This Request	Amount This Request	Quantity To Date	Amount To Date
Reconstructi on								
1 - SAP 013- 630-021 / Reconstructi on	36	2106.507 SELECT GRANULAR EMBANKMENT (CV) (P) (CU YD)	\$11.50	19000	0	\$0.00	19000	\$218,500.00
1 - SAP 013- 630-021 / Reconstructi on	38	2106.507 COMMON EMBANKMENT (CV) (P) (CU YD)	\$8.00	4181	0	\$0.00	4181	\$33,448.00
1 - SAP 013- 630-021 / Reconstructi on	39	2106.601/00015 DEWATERING (LUMP SUM)	\$42,000.00	1	0	\$0.00	1	\$42,000.00
1 - SAP 013- 630-021 / Reconstructi on	40	2130.523/00010 WATER (M GALLON)	\$50.00	400	0	\$0.00	90.8	\$4,540.00
1 - SAP 013- 630-021 / Reconstructi on	41	2211.507 AGGREGATE BASE (CV) CLASS 5 (P) (CU YD)	\$42.00	9420	0	\$0.00	9420	\$395,640.00
1 - SAP 013- 630-021 / Reconstructi on	42	2221.509/00090 SHOULDER BASE AGGREGATE CLASS 5 MOD (TON)	\$44.50	494	0	\$0.00	493.390 1123596	\$21,955.86
1 - SAP 013- 630-021 / Reconstructi on	43	2232.504/00060 MILL BITUMINOUS SURFACE (2.0") (SQ YD)	\$1.80	3974	0	\$0.00	0	\$0.00
1 - SAP 013- 630-021 / Reconstructi on	45	2357.506/00010 BITUMINOUS MATERIAL FOR TACK COAT (GALLON)	\$2.50	7319	0	\$0.00	4880	\$12,200.00
1 - SAP 013- 630-021 / Reconstructi on	46	2360.509/23205 TYPE SP 12.5 NON WEARING COURSE MIXTURE (3,B) (TON)	\$67.00	4799	0	\$0.00	4987.17	\$334,140.39
1 - SAP 013- 630-021 / Reconstructi on	47	2360.509/23300 TYPE SP 12.5 WEARING COURSE MIXTURE (3,C) (TON)	\$82.00	11693	0	\$0.00	11445.5 6	\$938,535.92
1 - SAP 013- 630-021 /	54	2501.502/04018 18" GS PIPE APRON (EACH)	\$300.00	14	0	\$0.00	12	\$3,600.00



Chisago County Public Works Department
 313 North Main Street, Room 400
 Center City, MN 55012
 Main: (651) 213-8700

Contract Item Status by Funding Breakdown

Funding Cat	Line	Item	Unit Price	Contract Quantity	Quantity This Request	Amount This Request	Quantity To Date	Amount To Date
Reconstruction								
1 - SAP 013-630-021 / Reconstruction	56	2501.502/05018 18" RC PIPE APRON (EACH)	\$2,900.00	8	0	\$0.00	8	\$23,200.00
1 - SAP 013-630-021 / Reconstruction	57	2501.502/05024 24" RC PIPE APRON (EACH)	\$3,200.00	6	0	\$0.00	6	\$19,200.00
1 - SAP 013-630-021 / Reconstruction	61	2501.502/44018 18" RC SAFETY APRON (EACH)	\$2,950.00	2	0	\$0.00	2	\$5,900.00
1 - SAP 013-630-021 / Reconstruction	62	2501.503/00018 18" CAS PIPE CULVERT (LIN FT)	\$38.00	320	0	\$0.00	261	\$9,918.00
1 - SAP 013-630-021 / Reconstruction	63	2501.503/24183 18" RC PIPE CULVERT DESIGN 3006 CLASS III (LIN FT)	\$46.00	367	0	\$0.00	359	\$16,514.00
1 - SAP 013-630-021 / Reconstruction	64	2501.503/24243 24" RC PIPE CULVERT DESIGN 3006 CLASS III (LIN FT)	\$57.50	300	0	\$0.00	268	\$15,410.00
1 - SAP 013-630-021 / Reconstruction	65	2502.503/10040 4" PERF TP PIPE DRAIN (LIN FT)	\$18.00	400	0	\$0.00	451	\$8,118.00
1 - SAP 013-630-021 / Reconstruction	83	2506.502/08020 ADJUST FRAME AND RING CASTING (EACH)	\$950.00	1	0	\$0.00	1	\$950.00
1 - SAP 013-630-021 / Reconstruction	87	2506.602/06450 ADJUST FRAME AND RING CASTING (SPECIAL) (EACH)	\$650.00	1	0	\$0.00	0	\$0.00
1 - SAP 013-630-021 / Reconstruction	92	2511.507/00013 RANDOM RIPRAP CLASS II (CU YD)	\$125.00	35.8	0	\$0.00	20.8	\$2,600.00
1 - SAP 013-630-021 /	94	2521.518/00040 4" CONCRETE WALK (SQ FT)	\$5.79	485	0	\$0.00	798	\$4,620.42



Chisago County Public Works Department
 313 North Main Street, Room 400
 Center City, MN 55012
 Main: (651) 213-8700

Contract Item Status by Funding Breakdown

Funding Cat	Line	Item	Unit Price	Contract Quantity	Quantity This Request	Amount This Request	Quantity To Date	Amount To Date
Reconstruction								
1 - SAP 013-630-021 / Reconstruction	98	2521.618/00400 CONCRETE CURB RAMP WALK (SQ FT)	\$9.50	528	0	\$0.00	115	\$1,092.50
1 - SAP 013-630-021 / Reconstruction	99	2531.503/02310 CONCRETE CURB AND GUTTER DESIGN B612 (LIN FT)	\$24.50	163	0	\$0.00	274	\$6,713.00
1 - SAP 013-630-021 / Reconstruction	100	2531.503/02320 CONCRETE CURB AND GUTTER DESIGN B624 (LIN FT)	\$20.25	9004	0	\$0.00	9379	\$189,924.75
1 - SAP 013-630-021 / Reconstruction	103	2531.504/00060 6" CONCRETE DRIVEWAY PAVEMENT (SQ YD)	\$71.00	340	0	\$0.00	674.2	\$47,868.20
1 - SAP 013-630-021 / Reconstruction	104	2531.504/00080 8" CONCRETE DRIVEWAY PAVEMENT (SQ YD)	\$84.00	503	0	\$0.00	458.3	\$38,497.20
1 - SAP 013-630-021 / Reconstruction	106	2540.602/00140 INSTALL MAIL BOX SUPPORT (EACH)	\$275.00	8	0	\$0.00	8	\$2,200.00
1 - SAP 013-630-021 / Reconstruction	108	2545.502/14080 LIGHT FOUNDATION DESIGN E (EACH)	\$1,052.09	5	0	\$0.00	5	\$5,260.45
1 - SAP 013-630-021 / Reconstruction	115	2545.602/23130 INSTALL LIGHTING UNIT (EACH)	\$1,123.50	5	0	\$0.00	0	\$0.00
1 - SAP 013-630-021 / Reconstruction	116	2554.502/00002 GUIDE POST TYPE B (EACH)	\$85.00	13	0	\$0.00	13	\$1,105.00
1 - SAP 013-630-021 / Reconstruction	117	2557.503/01223 WIRE FENCE DESIGN 48V-9322 (LIN FT)	\$80.00	50	0	\$0.00	50	\$4,000.00
1 - SAP 013-630-021 /	118	2563.601/00010 TRAFFIC CONTROL (LUMP SUM)	\$34,000.00	0.48	0	\$0.00	0.48	\$16,320.00



Chisago County Public Works Department
 313 North Main Street, Room 400
 Center City, MN 55012
 Main: (651) 213-8700

Contract Item Status by Funding Breakdown

Funding Cat	Line	Item	Unit Price	Contract Quantity	Quantity This Request	Amount This Request	Quantity To Date	Amount To Date
Reconstructi on								
1 - SAP 013-630-021 / Reconstructi on	119	2563.613/01100 PORTABLE CHANGEABLE MESSAGE SIGN (UNIT DAY)	\$75.00	100	0	\$0.00	93	\$6,975.00
1 - SAP 013-630-021 / Reconstructi on	120	2563.618/00100 CONSTRUCTION SIGN SPECIAL (SQ FT)	\$200.00	7	0	\$0.00	10	\$2,000.00
1 - SAP 013-630-021 / Reconstructi on	121	2564.602/01515 INSTALL SIGN (EACH)	\$450.00	5	0	\$0.00	12	\$5,400.00
1 - SAP 013-630-021 / Reconstructi on	122	2564.602/01516 INSTALL SIGN SPECIAL (EACH)	\$250.00	7	0	\$0.00	7	\$1,750.00
1 - SAP 013-630-021 / Reconstructi on	123	2564.602/01519 INSTALL SIGN PANEL SPECIAL (EACH)	\$250.00	3	0	\$0.00	3	\$750.00
1 - SAP 013-630-021 / Reconstructi on	124	2564.602/02340 DELINEATOR / MARKER (EACH)	\$350.00	1	0	\$0.00	1	\$350.00
1 - SAP 013-630-021 / Reconstructi on	125	2564.602/02350 DELINEATOR / MARKER PANEL (EACH)	\$95.00	6	0	\$0.00	6	\$570.00
1 - SAP 013-630-021 / Reconstructi on	126	2564.618/00010 SIGN (SQ FT)	\$73.50	441	0	\$0.00	441	\$32,413.50
1 - SAP 013-630-021 / Reconstructi on	127	2565.602/51717 RIGID PVC LOOP DETECTOR 6'X6' (EACH)	\$1,097.52	9	0	\$0.00	11	\$12,072.72
1 - SAP 013-630-021 / Reconstructi on	128	2565.616/00060 PEDESTRIAN CROSSWALK FLASHER SYSTEM (SYSTEM)	\$26,666.16	1	0	\$0.00	1	\$26,666.16
1 - SAP 013-630-021 /	129	2573.501/00025 STABILIZED CONSTRUCTION EXIT (LUMP SUM)	\$1,500.00	1	0	\$0.00	1	\$1,500.00



Chisago County Public Works Department
 313 North Main Street, Room 400
 Center City, MN 55012
 Main: (651) 213-8700

Contract Item Status by Funding Breakdown

Funding Cat	Line	Item	Unit Price	Contract Quantity	Quantity This Request	Amount This Request	Quantity To Date	Amount To Date
Reconstruction								
1 - SAP 013-630-021 / Reconstruction	130	2573.501/00030 EROSION CONTROL SUPERVISOR (LUMP SUM)	\$765.34	1	0	\$0.00	1	\$765.34
1 - SAP 013-630-021 / Reconstruction	131	2573.502/00110 STORM DRAIN INLET PROTECTION (EACH)	\$200.00	58	0	\$0.00	57	\$11,400.00
1 - SAP 013-630-021 / Reconstruction	132	2573.502/00140 CULVERT END CONTROLS (EACH)	\$220.00	9	0	\$0.00	7	\$1,540.00
1 - SAP 013-630-021 / Reconstruction	133	2573.503/00023 SILT FENCE, TYPE MS (LIN FT)	\$1.95	6915	0	\$0.00	7026	\$13,700.70
1 - SAP 013-630-021 / Reconstruction	134	2573.503/00060 SEDIMENT CONTROL LOG TYPE STRAW (LIN FT)	\$2.35	2078	0	\$0.00	1870	\$4,394.50
1 - SAP 013-630-021 / Reconstruction	136	2574.508/00013 FERTILIZER TYPE 3 (POUND)	\$0.74	2320	0	\$0.00	2505	\$1,853.70
1 - SAP 013-630-021 / Reconstruction	137	2575.504/00110 RAPID STABILIZATION METHOD 4 (SQ YD)	\$1.70	24484	0	\$0.00	4049	\$6,883.30
1 - SAP 013-630-021 / Reconstruction	138	2575.505/00021 SEEDING (ACRE)	\$525.00	8	0	\$0.00	8	\$4,200.00
1 - SAP 013-630-021 / Reconstruction	139	2575.505/00025 DISK ANCHORING (ACRE)	\$175.00	6.4	0	\$0.00	4.1	\$717.50
1 - SAP 013-630-021 / Reconstruction	140	2575.508/40006 HYDRAULIC STABILIZED FIBER MATRIX (POUND)	\$0.91	4609	0	\$0.00	4750	\$4,322.50
1 - SAP 013-630-021 /	141	2575.509/00030 MULCH MATERIAL TYPE 3 (TON)	\$650.00	9.7	0	\$0.00	9.35	\$6,077.50



Chisago County Public Works Department
 313 North Main Street, Room 400
 Center City, MN 55012
 Main: (651) 213-8700

Contract Item Status by Funding Breakdown								
Funding Cat	Line	Item	Unit Price	Contract Quantity	Quantity This Request	Amount This Request	Quantity To Date	Amount To Date
Reconstruction								
1 - SAP 013-630-021 / Reconstruction	142	2575.523/00020 RAPID STABILIZATION METHOD 3 (M GALLON)	\$495.00	10.5	0	\$0.00	6	\$2,970.00
1 - SAP 013-630-021 / Reconstruction	143	2575.608/25080 SEED TURFGRASS (POUND)	\$3.45	314	0	\$0.00	303.498 5507246	\$1,047.07
1 - SAP 013-630-021 / Reconstruction	144	2575.608/25100 SEED MESIC INSLOPE (POUND)	\$10.30	441	0	\$0.00	403	\$4,150.90
1 - SAP 013-630-021 / Reconstruction	145	2582.503/10104 4" SOLID LINE PAINT (LIN FT)	\$0.13	6532	0	\$0.00	6758	\$878.54
1 - SAP 013-630-021 / Reconstruction	146	2582.503/10106 6" SOLID LINE PAINT (LIN FT)	\$0.17	18911	0	\$0.00	19554	\$3,324.18
1 - SAP 013-630-021 / Reconstruction	147	2582.503/10124 24" SOLID LINE PAINT (LIN FT)	\$3.70	503	0	\$0.00	600	\$2,220.00
1 - SAP 013-630-021 / Reconstruction	148	2582.503/10204 4" BROKEN LINE PAINT (LIN FT)	\$0.13	1340	0	\$0.00	1370	\$178.10
1 - SAP 013-630-021 / Reconstruction	149	2582.503/10306 6" DOTTED LINE PAINT (LIN FT)	\$0.17	37	0	\$0.00	30	\$5.10
1 - SAP 013-630-021 / Reconstruction	151	2582.503/10404 4" DOUBLE SOLID LINE PAINT (LIN FT)	\$0.26	5904	0	\$0.00	5639	\$1,466.14
1 - SAP 013-630-021 / Reconstruction	152	2582.503/20104 4" SOLID LINE PAINT GROUND IN (WR) (LIN FT)	\$1.10	1089	0	\$0.00	678	\$745.80
1 - SAP 013-630-021 /	153	2582.503/20106 6" SOLID LINE PAINT GROUND IN (WR) (LIN FT)	\$1.30	1815	0	\$0.00	963	\$1,251.90



Chisago County Public Works Department
 313 North Main Street, Room 400
 Center City, MN 55012
 Main: (651) 213-8700

Contract Item Status by Funding Breakdown

Funding Cat	Line	Item	Unit Price	Contract Quantity	Quantity This Request	Amount This Request	Quantity To Date	Amount To Date
Reconstruction								
1 - SAP 013-630-021 / Reconstruction	154	2582.503/20306 6" DOTTED LINE PAINT GROUND IN (WR) (LIN FT)	\$1.30	23	0	\$0.00	43	\$55.90
1 - SAP 013-630-021 / Reconstruction	156	2582.518/01000 PAVEMENT MESSAGE PAINT (SQ FT)	\$4.00	995	0	\$0.00	988.7	\$3,954.80
1 - SAP 013-630-021 / Reconstruction	157	2582.518/08000 CROSSWALK PREFORM THERMOPLASTIC (SQ FT)	\$13.00	474	0	\$0.00	1080	\$14,040.00
1 - SAP 013-630-021 / Reconstruction	164	2411.601 REINFORCEMENT BARS (LS)	\$13,838.00	0.6	0	\$0.00	0.6	\$8,302.80
1 - SAP 013-630-021 / Reconstruction	165	2104.504 REMOVE BITUMINOUS PAVEMENT - OAK TO TH 95 (SQ YD)	\$5.50	4209.4	0	\$0.00	4209.4	\$23,151.70
1 - SAP 013-630-021 / Reconstruction	166	2360.509 TYPE SP 12.5 NON WEARING COURSE MIXTURE (3,B) - OAK TO TH 95 (TON)	\$82.00	837.88	0	\$0.00	837.88	\$68,706.16
1 - SAP 013-630-021 / Reconstruction	167	2360.601 BITUMINOUS PAVEMENT - DENSITY INCENTIVE (LUMP SUM)	\$46,355.97	1	1	\$46,355.97	1	\$46,355.97
1 - SAP 013-630-021 / Reconstruction	168	2360.601 BITUMINOUS PAVEMENT - SMOOTHNESS AND ALR INCENTIVE (LUMP SUM)	\$1,802.07	1	1	\$1,802.07	1	\$1,802.07
1 - SAP 013-630-021 / Storm Sewer	1	2021.501/00010 MOBILIZATION (LUMP SUM)	\$460,000.00	0.18	0	\$0.00	0.18	\$82,800.00
1 - SAP 013-630-021 / Storm Sewer	7	2104.502/00090 REMOVE BOX CULVERT (EACH)	\$3,700.00	2	0	\$0.00	2	\$7,400.00



Chisago County Public Works Department
 313 North Main Street, Room 400
 Center City, MN 55012
 Main: (651) 213-8700

Contract Item Status by Funding Breakdown

Funding Cat	Line	Item	Unit Price	Contract Quantity	Quantity This Request	Amount This Request	Quantity To Date	Amount To Date
1 - SAP 013-630-021 / Storm Sewer	8	2104.502/00100 REMOVE BOX CULVERT END (EACH)	\$3,700.00	4	0	\$0.00	4	\$14,800.00
1 - SAP 013-630-021 / Storm Sewer	37	2106.507 SELECT GRANULAR EMBANKMENT MOD 10% (CV) (P) (CU YD)	\$11.50	1022	0	\$0.00	0	\$0.00
1 - SAP 013-630-021 / Storm Sewer	50	2411.507/04000 STRUCTURE EXCAVATION CLASS E (CU YD)	\$10.00	2743	0	\$0.00	2743	\$27,430.00
1 - SAP 013-630-021 / Storm Sewer	51	2412.502/09050 9X4 PRECAST CONCRETE BOX CULVERT END SECTION (EACH)	\$12,000.00	2	0	\$0.00	2	\$24,000.00
1 - SAP 013-630-021 / Storm Sewer	52	2412.503/09040 9X4 PRECAST CONCRETE BOX CULVERT (LIN FT)	\$1,650.00	200	0	\$0.00	200	\$330,000.00
1 - SAP 013-630-021 / Storm Sewer	53	2451.507/00150 GRANULAR BEDDING (CV) (CU YD)	\$11.50	183	0	\$0.00	0	\$0.00
1 - SAP 013-630-021 / Storm Sewer	55	2501.502/05015 15" RC PIPE APRON (EACH)	\$2,700.00	2	0	\$0.00	2	\$5,400.00
1 - SAP 013-630-021 / Storm Sewer	58	2501.502/05030 30" RC PIPE APRON (EACH)	\$3,400.00	1	0	\$0.00	1	\$3,400.00
1 - SAP 013-630-021 / Storm Sewer	59	2501.502/05036 36" RC PIPE APRON (EACH)	\$3,800.00	1	0	\$0.00	1	\$3,800.00
1 - SAP 013-630-021 / Storm Sewer	67	2503.503/19155 15" RC PIPE SEWER DESIGN 3006 CLASS V (LIN FT)	\$38.10	1944	0	\$0.00	1938	\$73,837.80
1 - SAP 013-630-021 / Storm Sewer	68	2503.503/19183 18" RC PIPE SEWER DESIGN 3006 CLASS III (LIN FT)	\$42.40	1012	0	\$0.00	1012	\$42,908.80
1 - SAP 013-630-021 / Storm Sewer	69	2503.503/19243 24" RC PIPE SEWER DESIGN 3006 CLASS III (LIN FT)	\$52.50	2054	0	\$0.00	2054	\$107,835.00



Chisago County Public Works Department
 313 North Main Street, Room 400
 Center City, MN 55012
 Main: (651) 213-8700

Contract Item Status by Funding Breakdown

Funding Cat	Line	Item	Unit Price	Contract Quantity	Quantity This Request	Amount This Request	Quantity To Date	Amount To Date
1 - SAP 013-630-021 / Storm Sewer	70	2503.503/19303 30" RC PIPE SEWER DESIGN 3006 CLASS III (LIN FT)	\$73.00	477	0	\$0.00	477	\$34,821.00
1 - SAP 013-630-021 / Storm Sewer	71	2503.503/19363 36" RC PIPE SEWER DESIGN 3006 CLASS III (LIN FT)	\$101.40	267	0	\$0.00	267	\$27,073.80
1 - SAP 013-630-021 / Storm Sewer	82	2506.502/06000 CASTING ASSEMBLY (EACH)	\$1,000.00	50	0	\$0.00	48	\$48,000.00
1 - SAP 013-630-021 / Storm Sewer	84	2506.503/00070 CONSTRUCT DRAINAGE STRUCTURE DESIGN G (LIN FT)	\$960.00	82	0	\$0.00	82	\$78,720.00
1 - SAP 013-630-021 / Storm Sewer	85	2506.503/02420 CONSTRUCT DRAINAGE STRUCTURE DESIGN 48-4020 (LIN FT)	\$705.00	188.3	0	\$0.00	188.3	\$132,751.50
1 - SAP 013-630-021 / Storm Sewer	86	2506.503/03020 CONSTRUCT DRAINAGE STRUCTURE DESIGN 60-4020 (LIN FT)	\$600.00	16	0	\$0.00	16	\$9,600.00
1 - SAP 013-630-021 / Storm Sewer	90	2511.504/00017 GEOTEXTILE FILTER TYPE 7 (SQ YD)	\$3.80	398	0	\$0.00	169.9	\$645.62
1 - SAP 013-630-021 / Storm Sewer	91	2511.507/00012 RANDOM RIPRAP CLASS I (CU YD)	\$125.00	7	0	\$0.00	9.6	\$1,200.00
1 - SAP 013-630-021 / Storm Sewer	92	2511.507/00013 RANDOM RIPRAP CLASS II (CU YD)	\$125.00	18.8	0	\$0.00	20	\$2,500.00
1 - SAP 013-630-021 / Storm Sewer	93	2511.507/00014 RANDOM RIPRAP CLASS III (CU YD)	\$120.00	400	0	\$0.00	110.4	\$13,248.00
1 - SAP 013-630-021 / Storm Sewer	116	2554.502/00002 GUIDE POST TYPE B (EACH)	\$85.00	4	0	\$0.00	4	\$340.00



Chisago County Public Works Department
 313 North Main Street, Room 400
 Center City, MN 55012
 Main: (651) 213-8700

Contract Item Status by Funding Breakdown								
Funding Cat	Line	Item	Unit Price	Contract Quantity	Quantity This Request	Amount This Request	Quantity To Date	Amount To Date
1 - SAP 013-630-021 / Storm Sewer	118	2563.601/00010 TRAFFIC CONTROL (LUMP SUM)	\$34,000.00	0.18	0	\$0.00	0.18	\$6,120.00
1 - SAP 013-630-021 / Storm Sewer	135	2573.602/00030 TEMPORARY STREAM DIVERSION SYSTEM (EACH)	\$10,000.00	1	0	\$0.00	0	\$0.00
2 - RAB / Roadway	1	2021.501/00010 MOBILIZATION (LUMP SUM)	\$460,000.00	0.13	0	\$0.00	0.13	\$59,800.00
2 - RAB / Roadway	3	2101.502/00020 CLEARING (EACH)	\$199.00	1	0	\$0.00	8	\$1,592.00
2 - RAB / Roadway	4	2101.502/00030 GRUBBING (EACH)	\$199.00	1	0	\$0.00	8	\$1,592.00
2 - RAB / Roadway	5	2101.505/00020 CLEARING (ACRE)	\$2,501.00	0.5	0	\$0.00	0.5	\$1,250.50
2 - RAB / Roadway	6	2101.505/00030 GRUBBING (ACRE)	\$2,501.00	0.5	0	\$0.00	0.5	\$1,250.50
2 - RAB / Roadway	9	2104.502/00850 REMOVE GATE VALVE AND BOX (EACH)	\$1,800.00	2	0	\$0.00	4	\$7,200.00
2 - RAB / Roadway	10	2104.502/00880 REMOVE HYDRANT (EACH)	\$1,500.00	2	0	\$0.00	2	\$3,000.00
2 - RAB / Roadway	12	2104.502/01220 REMOVE SIGN (EACH)	\$25.00	1	0	\$0.00	1	\$25.00
2 - RAB / Roadway	13	2104.502/01580 REMOVE LIGHT FOUNDATION (EACH)	\$150.00	1	0	\$0.00	1	\$150.00
2 - RAB / Roadway	14	2104.502/02920 SALVAGE LIGHTING UNIT (EACH)	\$635.32	1	0	\$0.00	0	\$0.00



Chisago County Public Works Department
 313 North Main Street, Room 400
 Center City, MN 55012
 Main: (651) 213-8700

Contract Item Status by Funding Breakdown

Funding Cat	Line	Item	Unit Price	Contract Quantity	Quantity This Request	Amount This Request	Quantity To Date	Amount To Date
2 - RAB / Roadway	16	2104.502/03590 SALVAGE MAIL BOX SUPPORT (EACH)	\$200.00	2	0	\$0.00	2	\$400.00
2 - RAB / Roadway	17	2104.503/00195 SAWING CONCRETE PAVEMENT (FULL DEPTH) (LIN FT)	\$6.00	24	0	\$0.00	24	\$144.00
2 - RAB / Roadway	19	2104.503/00255 REMOVE PIPE CULVERTS (LIN FT)	\$17.00	108	0	\$0.00	108	\$1,836.00
2 - RAB / Roadway	25	2104.504/00070 REMOVE PAVEMENT (SQ YD)	\$2.00	2346	0	\$0.00	2352	\$4,704.00
2 - RAB / Roadway	28	2104.504/00120 REMOVE BITUMINOUS PAVEMENT (SQ YD)	\$2.00	2861	0	\$0.00	3535.4	\$7,070.80
2 - RAB / Roadway	29	2104.518/00100 REMOVE BITUMINOUS WALK (SQ FT)	\$2.00	10035	0	\$0.00	10200	\$20,400.00
2 - RAB / Roadway	31	2104.602/00300 REMOVE SIGN SPECIAL (EACH)	\$25.00	1	0	\$0.00	1	\$25.00
2 - RAB / Roadway	34	2106.507 EXCAVATION - COMMON (P) (CU YD)	\$6.00	4649	0	\$0.00	4649	\$27,894.00
2 - RAB / Roadway	35	2106.507 EXCAVATION - SUBGRADE (P) (CU YD)	\$8.50	3510	0	\$0.00	3510	\$29,835.00
2 - RAB / Roadway	36	2106.507 SELECT GRANULAR EMBANKMENT (CV) (P) (CU YD)	\$11.50	4794	0	\$0.00	4794	\$55,131.00
2 - RAB / Roadway	38	2106.507 COMMON EMBANKMENT (CV) (P) (CU YD)	\$8.00	1278	0	\$0.00	1278	\$10,224.00



Chisago County Public Works Department
 313 North Main Street, Room 400
 Center City, MN 55012
 Main: (651) 213-8700

Contract Item Status by Funding Breakdown								
Funding Cat	Line	Item	Unit Price	Contract Quantity	Quantity This Request	Amount This Request	Quantity To Date	Amount To Date
2 - RAB / Roadway	41	2211.507 AGGREGATE BASE (CV) CLASS 5 (P) (CU YD)	\$42.00	1630	0	\$0.00	1630	\$68,460.00
2 - RAB / Roadway	45	2357.506/00010 BITUMINOUS MATERIAL FOR TACK COAT (GALLON)	\$2.50	403	0	\$0.00	257.5	\$643.75
2 - RAB / Roadway	46	2360.509/23205 TYPE SP 12.5 NON WEARING COURSE MIXTURE (3,B) (TON)	\$67.00	303	0	\$0.00	303	\$20,301.00
2 - RAB / Roadway	47	2360.509/23300 TYPE SP 12.5 WEARING COURSE MIXTURE (3,C) (TON)	\$82.00	605	0	\$0.00	364.06	\$29,852.92
2 - RAB / Roadway	48	2360.509/24600 TYPE SP 12.5 WEARING COURSE MIXTURE (4;F) (TON)	\$114.00	477	0	\$0.00	530.99	\$60,532.86
2 - RAB / Roadway	49	2360.509/24605 TYPE SP 12.5 NON WEARING COURSE MIXTURE (4;F) (TON)	\$106.00	239	0	\$0.00	244.38	\$25,904.28
2 - RAB / Roadway	65	2502.503/10040 4" PERF TP PIPE DRAIN (LIN FT)	\$18.00	200	0	\$0.00	154	\$2,772.00
2 - RAB / Roadway	77	2504.602/00032 ADJUST GATE VALVE AND BOX (EACH)	\$500.00	2	0	\$0.00	0	\$0.00
2 - RAB / Roadway	87	2506.602/06450 ADJUST FRAME AND RING CASTING (SPECIAL) (EACH)	\$650.00	1	0	\$0.00	1	\$650.00
2 - RAB / Roadway	94	2521.518/00040 4" CONCRETE WALK (SQ FT)	\$5.79	14310	0	\$0.00	14185.298791019	\$82,132.88
2 - RAB / Roadway	95	2521.518/00070 7" CONCRETE WALK (SQ FT)	\$13.35	3525	0	\$0.00	3531	\$47,138.85



Chisago County Public Works Department
 313 North Main Street, Room 400
 Center City, MN 55012
 Main: (651) 213-8700

Contract Item Status by Funding Breakdown

Funding Cat	Line	Item	Unit Price	Contract Quantity	Quantity This Request	Amount This Request	Quantity To Date	Amount To Date
2 - RAB / Roadway	96	2521.518/00130 3" BITUMINOUS WALK (SQ FT)	\$1.75	11408	0	\$0.00	13140	\$22,995.00
2 - RAB / Roadway	97	2521.602/00030 DRILL AND GROUT REINF BAR (EPOXY COATED) (EACH)	\$8.50	33	0	\$0.00	33	\$280.50
2 - RAB / Roadway	98	2521.618/00400 CONCRETE CURB RAMP WALK (SQ FT)	\$9.50	1619	0	\$0.00	473.9	\$4,502.05
2 - RAB / Roadway	100	2531.503/02320 CONCRETE CURB AND GUTTER DESIGN B624 (LIN FT)	\$20.25	286	0	\$0.00	61	\$1,235.25
2 - RAB / Roadway	101	2531.503/18120 CONCRETE CURB AND GUTTER DESIGN R424 (LIN FT)	\$26.50	374	0	\$0.00	374	\$9,911.00
2 - RAB / Roadway	102	2531.503/19220 CONCRETE CURB AND GUTTER DESIGN S524 (LIN FT)	\$22.75	3687	0	\$0.00	3841	\$87,382.75
2 - RAB / Roadway	105	2531.618/00010 TRUNCATED DOMES (SQ FT)	\$50.00	160	0	\$0.00	76	\$3,800.00
2 - RAB / Roadway	106	2540.602/00140 INSTALL MAIL BOX SUPPORT (EACH)	\$275.00	2	0	\$0.00	2	\$550.00
2 - RAB / Roadway	107	2545.502/09030 LIGHTING UNIT TYPE 9-30 (EACH)	\$3,801.18	11	0	\$0.00	11	\$41,812.98
2 - RAB / Roadway	108	2545.502/14080 LIGHT FOUNDATION DESIGN E (EACH)	\$1,052.09	1	0	\$0.00	1	\$1,052.09
2 - RAB / Roadway	109	2545.502/16050 LIGHT FOUNDATION DESIGN STEEL E (EACH)	\$1,440.28	11	0	\$0.00	11	\$15,843.08



Chisago County Public Works Department
 313 North Main Street, Room 400
 Center City, MN 55012
 Main: (651) 213-8700

Contract Item Status by Funding Breakdown

Funding Cat	Line	Item	Unit Price	Contract Quantity	Quantity This Request	Amount This Request	Quantity To Date	Amount To Date
2 - RAB / Roadway	110	2545.502/21201 SERVICE CABINET -TYPE L1 (EACH)	\$9,718.81	1	0	\$0.00	1	\$9,718.81
2 - RAB / Roadway	111	2545.502/22510 SERVICE EQUIPMENT (EACH)	\$1,326.23	1	0	\$0.00	1	\$1,326.23
2 - RAB / Roadway	112	2545.502/22521 EQUIPMENT PAD B (EACH)	\$1,140.75	1	0	\$0.00	1	\$1,140.75
2 - RAB / Roadway	113	2545.503/01053 2" NON-METALLIC CONDUIT (LIN FT)	\$4.79	1500	0	\$0.00	1560	\$7,472.40
2 - RAB / Roadway	114	2545.503/03080 UNDERGROUND WIRE 1/C 8 AWG (LIN FT)	\$1.14	6500	0	\$0.00	6604	\$7,528.56
2 - RAB / Roadway	115	2545.602/23130 INSTALL LIGHTING UNIT (EACH)	\$1,123.50	1	0	\$0.00	0	\$0.00
2 - RAB / Roadway	118	2563.601/00010 TRAFFIC CONTROL (LUMP SUM)	\$34,000.00	0.13	0	\$0.00	0.13	\$4,420.00
2 - RAB / Roadway	124	2564.602/02340 DELINEATOR / MARKER (EACH)	\$350.00	2	0	\$0.00	2	\$700.00
2 - RAB / Roadway	125	2564.602/02350 DELINEATOR / MARKER PANEL (EACH)	\$95.00	4	0	\$0.00	4	\$380.00
2 - RAB / Roadway	126	2564.618/00010 SIGN (SQ FT)	\$73.50	173	0	\$0.00	173	\$12,715.50
2 - RAB / Roadway	128	2565.616/00060 PEDESTRIAN CROSSWALK FLASHER SYSTEM (SYSTEM)	\$26,666.16	1	0	\$0.00	1	\$26,666.16



Contract Item Status by Funding Breakdown

Funding Cat	Line	Item	Unit Price	Contract Quantity	Quantity This Request	Amount This Request	Quantity To Date	Amount To Date
2 - RAB / Roadway	131	2573.502/00110 STORM DRAIN INLET PROTECTION (EACH)	\$200.00	16	0	\$0.00	16	\$3,200.00
2 - RAB / Roadway	133	2573.503/00023 SILT FENCE, TYPE MS (LIN FT)	\$1.95	474	0	\$0.00	405	\$789.75
2 - RAB / Roadway	134	2573.503/00060 SEDIMENT CONTROL LOG TYPE STRAW (LIN FT)	\$2.35	729	0	\$0.00	764	\$1,795.40
2 - RAB / Roadway	136	2574.508/00013 FERTILIZER TYPE 3 (POUND)	\$0.74	549	150	\$111.00	555	\$410.70
2 - RAB / Roadway	138	2575.505/00021 SEEDING (ACRE)	\$525.00	1.9	0.5	\$262.50	1.7	\$892.50
2 - RAB / Roadway	139	2575.505/00025 DISK ANCHORING (ACRE)	\$175.00	1.5	0	\$0.00	1	\$175.00
2 - RAB / Roadway	140	2575.508/40006 HYDRAULIC STABILIZED FIBER MATRIX (POUND)	\$0.91	1306	850	\$773.50	3500	\$3,185.00
2 - RAB / Roadway	141	2575.509/00030 MULCH MATERIAL TYPE 3 (TON)	\$650.00	2.2	0	\$0.00	1.6	\$1,040.00
2 - RAB / Roadway	142	2575.523/00020 RAPID STABILIZATION METHOD 3 (M GALLON)	\$495.00	3	0	\$0.00	2	\$990.00
2 - RAB / Roadway	143	2575.608/25080 SEED TURFGRASS (POUND)	\$3.45	89	20	\$69.00	20	\$69.00
2 - RAB / Roadway	144	2575.608/25100 SEED MESIC INSLOPE (POUND)	\$10.30	105	50	\$515.00	165	\$1,699.50
2 - RAB / Roadway	152	2582.503/20104 4" SOLID LINE PAINT GROUND IN (WR) (LIN FT)	\$1.10	1543	0	\$0.00	921	\$1,013.10



Chisago County Public Works Department
 313 North Main Street, Room 400
 Center City, MN 55012
 Main: (651) 213-8700

Contract Item Status by Funding Breakdown

Funding Cat	Line	Item	Unit Price	Contract Quantity	Quantity This Request	Amount This Request	Quantity To Date	Amount To Date
2 - RAB / Roadway	153	2582.503/20106 6" SOLID LINE PAINT GROUND IN (WR) (LIN FT)	\$1.30	2041	0	\$0.00	1086	\$1,411.80
2 - RAB / Roadway	154	2582.503/20306 6" DOTTED LINE PAINT GROUND IN (WR) (LIN FT)	\$1.30	23	0	\$0.00	43	\$55.90
2 - RAB / Roadway	155	2582.503/76312 12" DOTTED LINE PREFORM THERMO GROUND IN (LIN FT)	\$20.00	43	0	\$0.00	26	\$520.00
2 - RAB / Roadway	156	2582.518/01000 PAVEMENT MESSAGE PAINT (SQ FT)	\$4.00	31	0	\$0.00	31	\$124.00
2 - RAB / Roadway	158	2582.518/08020 CROSSWALK PREFORM THERMOPLASTIC GROUND IN (SQ FT)	\$15.00	180	0	\$0.00	180	\$2,700.00
2 - RAB / Storm Sewer	1	2021.501/00010 MOBILIZATION (LUMP SUM)	\$460,000.00	0.04	0	\$0.00	0.04	\$18,400.00
2 - RAB / Storm Sewer	58	2501.502/05030 30" RC PIPE APRON (EACH)	\$3,400.00	2	0	\$0.00	2	\$6,800.00
2 - RAB / Storm Sewer	60	2501.502/44015 15" RC SAFETY APRON (EACH)	\$2,775.00	2	0	\$0.00	2	\$5,550.00
2 - RAB / Storm Sewer	67	2503.503/19155 15" RC PIPE SEWER DESIGN 3006 CLASS V (LIN FT)	\$38.10	1363	0	\$0.00	1389	\$52,920.90
2 - RAB / Storm Sewer	70	2503.503/19303 30" RC PIPE SEWER DESIGN 3006 CLASS III (LIN FT)	\$73.00	470	0	\$0.00	470	\$34,310.00
2 - RAB / Storm Sewer	82	2506.502/06000 CASTING ASSEMBLY (EACH)	\$1,000.00	18	0	\$0.00	18	\$18,000.00



Chisago County Public Works Department
 313 North Main Street, Room 400
 Center City, MN 55012
 Main: (651) 213-8700

Contract Item Status by Funding Breakdown

Funding Cat	Line	Item	Unit Price	Contract Quantity	Quantity This Request	Amount This Request	Quantity To Date	Amount To Date
2 - RAB / Storm Sewer	84	2506.503/00070 CONSTRUCT DRAINAGE STRUCTURE DESIGN G (LIN FT)	\$960.00	12.2	0	\$0.00	12.2	\$11,712.00
2 - RAB / Storm Sewer	85	2506.503/02420 CONSTRUCT DRAINAGE STRUCTURE DESIGN 48-4020 (LIN FT)	\$705.00	88.4	0	\$0.00	88.4	\$62,322.00
2 - RAB / Storm Sewer	86	2506.503/03020 CONSTRUCT DRAINAGE STRUCTURE DESIGN 60-4020 (LIN FT)	\$600.00	10.9	0	\$0.00	10.9	\$6,540.00
2 - RAB / Storm Sewer	92	2511.507/00013 RANDOM RIPRAP CLASS II (CU YD)	\$125.00	8.2	0	\$0.00	10.8	\$1,350.00
2 - RAB / Storm Sewer	116	2554.502/00002 GUIDE POST TYPE B (EACH)	\$85.00	4	0	\$0.00	4	\$340.00
2 - RAB / Storm Sewer	118	2563.601/00010 TRAFFIC CONTROL (LUMP SUM)	\$34,000.00	0.04	0	\$0.00	0.04	\$1,360.00
3 - SRTS	1	2021.501/00010 MOBILIZATION (LUMP SUM)	\$460,000.00	0.05	0	\$0.00	0.05	\$23,000.00
3 - SRTS	3	2101.502/00020 CLEARING (EACH)	\$199.00	50	0	\$0.00	58	\$11,542.00
3 - SRTS	4	2101.502/00030 GRUBBING (EACH)	\$199.00	50	0	\$0.00	59	\$11,741.00
3 - SRTS	5	2101.505/00020 CLEARING (ACRE)	\$2,501.00	0.1	0	\$0.00	0.1	\$250.10
3 - SRTS	6	2101.505/00030 GRUBBING (ACRE)	\$2,501.00	0.1	0	\$0.00	0.1	\$250.10
3 - SRTS	9	2104.502/00850 REMOVE GATE VALVE AND BOX (EACH)	\$1,800.00	2	0	\$0.00	2	\$3,600.00



Chisago County Public Works Department
 313 North Main Street, Room 400
 Center City, MN 55012
 Main: (651) 213-8700

Contract Item Status by Funding Breakdown

Funding Cat	Line	Item	Unit Price	Contract Quantity	Quantity This Request	Amount This Request	Quantity To Date	Amount To Date
3 - SRTS	10	2104.502/00880 REMOVE HYDRANT (EACH)	\$1,500.00	2	0	\$0.00	2	\$3,000.00
3 - SRTS	18	2104.503/00205 SAWING BITUMINOUS PAVEMENT (FULL DEPTH) (LIN FT)	\$1.90	70	0	\$0.00	160	\$304.00
3 - SRTS	21	2104.503/00315 REMOVE CURB AND GUTTER (LIN FT)	\$4.50	78	0	\$0.00	230	\$1,035.00
3 - SRTS	27	2104.504/00110 REMOVE BITUMINOUS DRIVEWAY PAVEMENT (SQ YD)	\$2.00	161	0	\$0.00	37.9	\$75.80
3 - SRTS	34	2106.507 EXCAVATION - COMMON (P) (CU YD)	\$6.00	3181	0	\$0.00	3181	\$19,086.00
3 - SRTS	38	2106.507 COMMON EMBANKMENT (CV) (P) (CU YD)	\$8.00	7288	0	\$0.00	7288	\$58,304.00
3 - SRTS	41	2211.507 AGGREGATE BASE (CV) CLASS 5 (P) (CU YD)	\$42.00	881	0	\$0.00	881	\$37,002.00
3 - SRTS	47	2360.509/23300 TYPE SP 12.5 WEARING COURSE MIXTURE (3,C) (TON)	\$82.00	36	0	\$0.00	0	\$0.00
3 - SRTS	76	2504.602/00026 ADJUST HYDRANT AND GATE VALVE (EACH)	\$1,500.00	1	0	\$0.00	1	\$1,500.00
3 - SRTS	94	2521.518/00040 4" CONCRETE WALK (SQ FT)	\$5.79	3546	0	\$0.00	3564.30 0518134 7	\$20,637.30
3 - SRTS	96	2521.518/00130 3" BITUMINOUS WALK (SQ FT)	\$1.75	37928	0	\$0.00	37223	\$65,140.25



Chisago County Public Works Department
 313 North Main Street, Room 400
 Center City, MN 55012
 Main: (651) 213-8700

Contract Item Status by Funding Breakdown								
Funding Cat	Line	Item	Unit Price	Contract Quantity	Quantity This Request	Amount This Request	Quantity To Date	Amount To Date
3 - SRTS	97	2521.602/00030 DRILL AND GROUT REINF BAR (EPOXY COATED) (EACH)	\$8.50	60	0	\$0.00	76	\$646.00
3 - SRTS	98	2521.618/00400 CONCRETE CURB RAMP WALK (SQ FT)	\$9.50	2302	0	\$0.00	2919.5	\$27,735.25
3 - SRTS	100	2531.503/02320 CONCRETE CURB AND GUTTER DESIGN B624 (LIN FT)	\$20.25	32	0	\$0.00	91	\$1,842.75
3 - SRTS	105	2531.618/00010 TRUNCATED DOMES (SQ FT)	\$50.00	420	0	\$0.00	535	\$26,750.00
3 - SRTS	118	2563.601/00010 TRAFFIC CONTROL (LUMP SUM)	\$34,000.00	0.05	0	\$0.00	0.05	\$1,700.00
3 - SRTS	132	2573.502/00140 CULVERT END CONTROLS (EACH)	\$220.00	8	0	\$0.00	7	\$1,540.00
3 - SRTS	133	2573.503/00023 SILT FENCE, TYPE MS (LIN FT)	\$1.95	889	0	\$0.00	950	\$1,852.50
3 - SRTS	134	2573.503/00060 SEDIMENT CONTROL LOG TYPE STRAW (LIN FT)	\$2.35	597	0	\$0.00	656	\$1,541.60
3 - SRTS	136	2574.508/00013 FERTILIZER TYPE 3 (POUND)	\$0.74	404	0	\$0.00	375	\$277.50
3 - SRTS	137	2575.504/00110 RAPID STABILIZATION METHOD 4 (SQ YD)	\$1.70	5450	0	\$0.00	1920	\$3,264.00
3 - SRTS	138	2575.505/00021 SEEDING (ACRE)	\$525.00	1.8	0	\$0.00	1.71	\$897.75



Chisago County Public Works Department
 313 North Main Street, Room 400
 Center City, MN 55012
 Main: (651) 213-8700

Contract Item Status by Funding Breakdown

Funding Cat	Line	Item	Unit Price	Contract Quantity	Quantity This Request	Amount This Request	Quantity To Date	Amount To Date
3 - SRTS	140	2575.508/40006 HYDRAULIC STABILIZED FIBER MATRIX (POUND)	\$0.91	3420	0	\$0.00	5050	\$4,595.50
3 - SRTS	142	2575.523/00020 RAPID STABILIZATION METHOD 3 (M GALLON)	\$495.00	8	0	\$0.00	4	\$1,980.00
3 - SRTS	143	2575.608/25080 SEED TURFGRASS (POUND)	\$3.45	234	0	\$0.00	215	\$741.75
3 - SRTS	144	2575.608/25100 SEED MESIC INSLOPE (POUND)	\$10.30	80	0	\$0.00	11	\$113.30
3 - SRTS	162	2104.502 REMOVE UTILITY VAULT (EACH)	\$300.00	1	0	\$0.00	1	\$300.00
3 - SRTS	163	2231.507 BITUMINOUS PATCHING MIXTURE (TON)	\$150.00	21	0	\$0.00	25	\$3,750.00
4 - City Local	1	2021.501/00010 MOBILIZATION (LUMP SUM)	\$460,000.00	0.05	0	\$0.00	0.05	\$23,000.00
4 - City Local	12	2104.502/01220 REMOVE SIGN (EACH)	\$25.00	2	0	\$0.00	2	\$50.00
4 - City Local	16	2104.502/03590 SALVAGE MAIL BOX SUPPORT (EACH)	\$200.00	4	0	\$0.00	4	\$800.00
4 - City Local	18	2104.503/00205 SAWING BITUMINOUS PAVEMENT (FULL DEPTH) (LIN FT)	\$1.90	40	0	\$0.00	431	\$818.90
4 - City Local	20	2104.503/00270 REMOVE WATER MAIN (LIN FT)	\$15.00	110	0	\$0.00	142.5	\$2,137.50
4 - City Local	21	2104.503/00315 REMOVE CURB AND GUTTER (LIN FT)	\$4.50	140	0	\$0.00	323	\$1,453.50



Chisago County Public Works Department
 313 North Main Street, Room 400
 Center City, MN 55012
 Main: (651) 213-8700

Contract Item Status by Funding Breakdown								
Funding Cat	Line	Item	Unit Price	Contract Quantity	Quantity This Request	Amount This Request	Quantity To Date	Amount To Date
4 - City Local	23	2104.503/00820 REMOVE STEEL CASING (LIN FT)	\$10.00	100	0	\$0.00	100	\$1,000.00
4 - City Local	27	2104.504/00110 REMOVE BITUMINOUS DRIVEWAY PAVEMENT (SQ YD)	\$2.00	9	0	\$0.00	215	\$430.00
4 - City Local	28	2104.504/00120 REMOVE BITUMINOUS PAVEMENT (SQ YD)	\$2.00	575	0	\$0.00	979.2	\$1,958.40
4 - City Local	30	2104.518/00140 REMOVE CONCRETE WALK (SQ FT)	\$2.00	733	0	\$0.00	991	\$1,982.00
4 - City Local	34	2106.507 EXCAVATION - COMMON (P) (CU YD)	\$6.00	1240	0	\$0.00	1240	\$7,440.00
4 - City Local	35	2106.507 EXCAVATION - SUBGRADE (P) (CU YD)	\$8.50	850	0	\$0.00	850	\$7,225.00
4 - City Local	36	2106.507 SELECT GRANULAR EMBANKMENT (CV) (P) (CU YD)	\$11.50	859	0	\$0.00	859	\$9,878.50
4 - City Local	38	2106.507 COMMON EMBANKMENT (CV) (P) (CU YD)	\$8.00	379	0	\$0.00	379	\$3,032.00
4 - City Local	41	2211.507 AGGREGATE BASE (CV) CLASS 5 (P) (CU YD)	\$42.00	370	0	\$0.00	370	\$15,540.00
4 - City Local	45	2357.506/00010 BITUMINOUS MATERIAL FOR TACK COAT (GALLON)	\$2.50	122	0	\$0.00	110	\$275.00
4 - City Local	47	2360.509/23300 TYPE SP 12.5 WEARING COURSE MIXTURE (3,C) (TON)	\$82.00	334	0	\$0.00	386.18	\$31,666.76



Contract Item Status by Funding Breakdown

Funding Cat	Line	Item	Unit Price	Contract Quantity	Quantity This Request	Amount This Request	Quantity To Date	Amount To Date
4 - City Local	63	2501.503/24183 18" RC PIPE CULVERT DESIGN 3006 CLASS III (LIN FT)	\$46.00	29	0	\$0.00	29	\$1,334.00
4 - City Local	66	2503.503/13120 12" PVC PIPE SEWER (LIN FT)	\$54.00	302	0	\$0.00	302	\$16,308.00
4 - City Local	72	2503.602/00310 CONNECT TO EXISTING MANHOLES (SAN) (EACH)	\$4,500.00	1	0	\$0.00	1	\$4,500.00
4 - City Local	73	2503.603/31200 20" STEEL CASING PIPE (LIN FT)	\$140.00	90	0	\$0.00	90	\$12,600.00
4 - City Local	74	2504.602/00010 CONNECT TO EXISTING WATER MAIN (EACH)	\$4,000.00	4	0	\$0.00	4	\$16,000.00
4 - City Local	75	2504.602/00020 HYDRANT (EACH)	\$7,600.00	4	0	\$0.00	5	\$38,000.00
4 - City Local	78	2504.602/00806 6" GATE VALVE AND BOX (EACH)	\$2,884.00	4	0	\$0.00	4	\$11,536.00
4 - City Local	79	2504.603/01062 6" WATERMAIN DUCTILE IRON CL 52 (LIN FT)	\$54.00	56	0	\$0.00	65.5	\$3,537.00
4 - City Local	81	2504.603/04160 16" STEEL CASING PIPE (LIN FT)	\$100.00	164	0	\$0.00	163	\$16,300.00
4 - City Local	82	2506.502/06000 CASTING ASSEMBLY (EACH)	\$1,000.00	2	0	\$0.00	3	\$3,000.00
4 - City Local	83	2506.502/06020 ADJUST FRAME AND RING CASTING (EACH)	\$950.00	1	0	\$0.00	1	\$950.00



Chisago County Public Works Department
 313 North Main Street, Room 400
 Center City, MN 55012
 Main: (651) 213-8700

Contract Item Status by Funding Breakdown

Funding Cat	Line	Item	Unit Price	Contract Quantity	Quantity This Request	Amount This Request	Quantity To Date	Amount To Date
4 - City Local	88	2506.603/30000 CONSTRUCT DRAINAGE STRUCTURE DESIGN SPECIAL (LIN FT)	\$600.00	12.8	0	\$0.00	12.8	\$7,680.00
4 - City Local	89	2506.603/50000 RECONSTRUCT DRAINAGE STRUCTURE SPECIAL (LIN FT)	\$516.00	6.2	0	\$0.00	10.7	\$5,521.20
4 - City Local	94	2521.518/00040 4" CONCRETE WALK (SQ FT)	\$5.79	760	0	\$0.00	858	\$4,967.82
4 - City Local	99	2531.503/02310 CONCRETE CURB AND GUTTER DESIGN B612 (LIN FT)	\$24.50	147	0	\$0.00	385	\$9,432.50
4 - City Local	100	2531.503/02320 CONCRETE CURB AND GUTTER DESIGN B624 (LIN FT)	\$20.25	570	0	\$0.00	570	\$11,542.50
4 - City Local	104	2531.504/00080 8" CONCRETE DRIVEWAY PAVEMENT (SQ YD)	\$84.00	325	0	\$0.00	544.3	\$45,721.20
4 - City Local	106	2540.602/00140 INSTALL MAIL BOX SUPPORT (EACH)	\$275.00	4	0	\$0.00	4	\$1,100.00
4 - City Local	118	2563.601/00010 TRAFFIC CONTROL (LUMP SUM)	\$34,000.00	0.05	0	\$0.00	0.05	\$1,700.00
4 - City Local	125	2564.602/02350 DELINEATOR / MARKER PANEL (EACH)	\$95.00	3	0	\$0.00	3	\$285.00
4 - City Local	126	2564.618/00010 SIGN (SQ FT)	\$73.50	68	0	\$0.00	68	\$4,998.00
4 - City Local	128	2565.616/00060 PEDESTRIAN CROSSWALK FLASHER SYSTEM (SYSTEM)	\$26,666.16	1	0	\$0.00	1	\$26,666.16



Chisago County Public Works Department
 313 North Main Street, Room 400
 Center City, MN 55012
 Main: (651) 213-8700

Contract Item Status by Funding Breakdown

Funding Cat	Line	Item	Unit Price	Contract Quantity	Quantity This Request	Amount This Request	Quantity To Date	Amount To Date
4 - City Local	131	2573.502/00110 STORM DRAIN INLET PROTECTION (EACH)	\$200.00	4	0	\$0.00	5	\$1,000.00
4 - City Local	134	2573.503/00060 SEDIMENT CONTROL LOG TYPE STRAW (LIN FT)	\$2.35	274	0	\$0.00	420	\$987.00
4 - City Local	136	2574.508/00013 FERTILIZER TYPE 3 (POUND)	\$0.74	105	0	\$0.00	15	\$11.10
4 - City Local	137	2575.504/00110 RAPID STABILIZATION METHOD 4 (SQ YD)	\$1.70	1236	0	\$0.00	1215	\$2,065.50
4 - City Local	138	2575.505/00021 SEEDING (ACRE)	\$525.00	0.6	0	\$0.00	0.5	\$262.50
4 - City Local	139	2575.505/00025 DISK ANCHORING (ACRE)	\$175.00	0.5	0	\$0.00	0.6	\$105.00
4 - City Local	140	2575.508/40006 HYDRAULIC STABILIZED FIBER MATRIX (POUND)	\$0.91	110	0	\$0.00	125	\$113.75
4 - City Local	141	2575.509/00030 MULCH MATERIAL TYPE 3 (TON)	\$650.00	0.5	0	\$0.00	0.5	\$325.00
4 - City Local	142	2575.523/00020 RAPID STABILIZATION METHOD 3 (M GALLON)	\$495.00	0.5	0	\$0.00	0	\$0.00
4 - City Local	143	2575.608/25080 SEED TURFGRASS (POUND)	\$3.45	8	0	\$0.00	6.50144 92754	\$22.43
4 - City Local	144	2575.608/25100 SEED MESIC INSLOPE (POUND)	\$10.30	22	0	\$0.00	25	\$257.50
4 - City Local	147	2582.503/10124 24" SOLID LINE PAINT (LIN FT)	\$3.70	42	0	\$0.00	45	\$166.50



Chisago County Public Works Department
 313 North Main Street, Room 400
 Center City, MN 55012
 Main: (651) 213-8700

Contract Item Status by Funding Breakdown

Funding Cat	Line	Item	Unit Price	Contract Quantity	Quantity This Request	Amount This Request	Quantity To Date	Amount To Date
4 - City Local	151	2582.503/10404 4" DOUBLE SOLID LINE PAINT (LIN FT)	\$0.26	776	0	\$0.00	785	\$204.10
4 - City Local	152	2582.503/20104 4" SOLID LINE PAINT GROUND IN (WR) (LIN FT)	\$1.10	237	0	\$0.00	139	\$152.90
4 - City Local	155	2582.503/76312 12" DOTTED LINE PREFORM THERMO GROUND IN (LIN FT)	\$20.00	43	0	\$0.00	25	\$500.00
4 - City Local	158	2582.518/08020 CROSSWALK PREFORM THERMOPLASTIC GROUND IN (SQ FT)	\$15.00	180	0	\$0.00	180	\$2,700.00
4 - City Local	159	2504.603 10" WATERMAIN C900 (LIN FT)	\$76.00	415	0	\$0.00	446.35	\$33,922.60
4 - City Local	160	2504.602 10" GATE VALVE & BOX (EACH)	\$7,370.00	1	0	\$0.00	3	\$22,110.00
4 - City Local	164	2411.601 REINFORCEMENT BARS (LS)	\$13,838.00	0.4	0	\$0.00	0.4	\$5,535.20
Totals:						\$49,889.04		\$6,752,442.16



Prepared By: Dan Meyer, Police Chief

Presenter: Dan Meyer, Police Chief

Date: 01/28/2026

Board & Commission: City Council

Subject: Approval of the Financing Agreement with KS State Bank for the Purchase and Upfitting of Four Squad Cars

As part of the 2026 budget and equipment bond discussions, there was consensus among the city council to move forward with financing the purchase and the upfitting of four police squad cars. I reached out to a couple of banking institutions and received a financing proposal from KS State Bank. The City currently uses KS State Bank to finance a fire department pumper truck purchased in 2019 and three squad cars purchased in 2025.

KS State Bank provided a 60-month (5 year) financing proposal of \$299,908.01 which would cover the total cost of all four vehicles including equipment and upfitting. The annual payments under the terms of the financing plan will be \$66,510.30 with the first payment due at closing.

With the purchase of these new vehicles, we will be removing a 2017 Ford Explorer, a 2018 Ford Explorer, and a 2019 Dodge Durango out of our squad rotation. Unless the vehicles can be utilized in other city departments, the vehicles will be sold at public auction.

Requested City Council Action:

To approve the financing agreement from KS State Bank (attached) and to authorize the City Administrator, Matthew Hill, to sign the agreements necessary to effect the purchase and financing of the new squad cars.

Voting Requirements:

Voting Options Simple Majority



2627 KFB PLAZA, SUITE 110E | 877-587-4054
MANHATTAN, KS 66503

SENT VIA EMAIL: dmeyer@northbranchmn.gov

January 27, 2026

Dan Meyer
City of North Branch, Minnesota

Re: Financing for City of North Branch, Minnesota for Three (3) 2026 Ford Police Interceptor Vehicles with Upfitting and One (1) 2026 Ford F150 Responder with Upfitting

To Whom it May Concern:

Thank you for choosing KS StateBank as your financing source. Attached hereto, please find the Contract and documentation for your review and completion. Included is a Documentation Instruction sheet to guide you through the process. **All required documentation must be received by 3:00pm CST in order to fund the following business day.**

The interest rate you have been quoted is valid through February 06, 2026 (subject to the Conditions to Funding on the attached Documentation Instructions).

Please note that depending on circumstances, we reserve the right to charge a reasonable fee to Obligor/broker, if this transaction is not funded. This fee is for expenses incurred and services performed related to the processing of the transaction. This fee will NOT be charged if the transaction is funded by Obligee.

If you have any questions regarding the documentation please feel free to contact me at (877) 587-4054.

Sincerely,

Marissa Uhrich
Client Relations

DOCUMENTATION INSTRUCTIONS

The instructions listed below should be followed when completing the enclosed documentation. ***Please sign in blue ink and print on single sided paper only.*** Documentation completed improperly will delay funding. If you have any questions regarding the Conditions to Funding, instructions or the documentation, please call us at (877) 587-4054.

1. Attached Documentation

1. Government Obligation Contract

*An authorized individual that is with the Obligor should sign on the first space provided. ***All original signatures are required for funding.***

2. Exhibit A - Description of Equipment

*Review equipment description. Complete serial number/VIN if applicable.

*List the location where the equipment will be located after delivery/installation.

3. Exhibit B - Payment Schedule

*Sign and print name and title.

4. Exhibit C - Acceptance of Obligation

*Sign and print name and title.

5. Exhibit D - Obligor Resolution

*Type in the date of the meeting in which the purchase was approved.

*Print or type the name and title of the individual(s) who is authorized to execute the Contract.

*The board chairman or other authorized member of the Obligor's Governing Body must sign the Resolution where indicated.

*The board secretary or board clerk of Obligor must attest the Resolution where indicated.

6. Exhibit E - Officer's Certificate

*Sign and print name and title.

*Please list the Source of Funds for the Contract Payments.

7. Exhibit F - Payment Request & Equipment Acceptance Form

*Do Not Return until you need to request funds from the Vendor Payable Account.

8. Exhibit G - Signature Card

*Sign and print name and title.

*An additional individual may sign as an authorized individual, if desired.

9. Exhibit H - Obligor Acknowledgement

*Complete information as indicated.

10. Exhibit I - Bank Qualified Certificate

*Sign and print name and title.

11. Insurance Requirements

*Complete insurance company contact information where indicated.

12. Debit Authorization - (Preferred)

*Complete form and attach a voided check.

13. 8038G IRS Form

*Please read 8038 Review Form.

*In Box 2, type Employer Identification Number.

*Sign and print name and title.

2. Additional Documentation Required

1. First payment check as stated on attached invoice

3. Condition to Funding

If, for any reason: (i) the required documentation is not returned by May 23, 2026, is incomplete, or has unresolved issues relating thereto, or (ii) on, or prior to the return of the documentation, there is a change of circumstance, including but not limited to changes in the federal corporate income tax rate or reducing/capping the tax-exempt interest benefit, which adversely affects the expectations, rights or security of the Obligee or its assignees; then Obligee or its assignees reserve the right to withdraw/void its offer to fund this transaction in its entirety. *Neither KS StateBank nor Baystone Government Finance is acting as an advisor to the municipal entity/obligated person and neither owes a fiduciary duty pursuant to Section 15B of the Exchange Act of 1934.*

All documentation should be returned to:

KS StateBank
2627 KFB Plaza, STE 110E
Manhattan, Kansas 66503

GOVERNMENT OBLIGATION CONTRACT

Obligor

City of North Branch, Minnesota
6408 Elm Street
North Branch, Minnesota 55056

Obligee

KS StateBank
1010 Westloop; P.O. Box 69
Manhattan, Kansas 66505-0069

Dated as of January 26, 2026

This Government Obligation Contract dated as of the date listed above is between Obligee and Obligor listed directly above. Obligee desires to finance the purchase of the Equipment described in Exhibit A to Obligor and Obligor desires to have Obligee finance the purchase of the Equipment subject to the terms and conditions of this Contract which are set forth below.

Definitions

Section 1.01 Definitions. The following terms will have the meanings indicated below unless the context clearly requires otherwise:

- "Additional Schedule" refers to the proper execution of additional schedules to Exhibit A and Exhibit B, as well as other exhibits or documents that may be required by the Obligee all of which relate to the financing of additional Equipment.
- "Budget Year" means the Obligor's fiscal year.
- "Commencement Date" is the date when Obligor's obligation to pay Contract Payments begins.
- "Contract" means this Government Obligation Contract and all Exhibits attached hereto, all addenda, modifications, schedules, refinancings, guarantees and all documents relied upon by Obligee prior to execution of this Contract.
- "Contract Payments" means the payments Obligor is required to make under this Contract as set forth on Exhibit B.
- "Contract Term" means the Original Term and all Renewal Terms.
- "Exhibit" includes the Exhibits attached hereto, and any "Additional Schedule", whether now existing or subsequently created.
- "Equipment" means all of the items of Equipment listed on Exhibit A and any Additional Schedule, whether now existing or subsequently created, and all replacements, restorations, modifications and improvements.
- "Government" as used in the title hereof means a State or a political subdivision of the State within the meaning of Section 103(a) of the Internal Revenue Code of 1986, as amended ("Code"), or a constituted authority or district authorized to issue obligations on behalf of the State or political subdivision of the State within the meaning of Treasury Regulation 1.103-1(b), or a qualified volunteer fire company within the meaning of section 150(e)(1) of the Code.
- "Obligee" means the entity originally listed above as Obligee or any of its assignees.
- "Obligor" means the entity listed above as Obligor and which is financing the Equipment through Obligee under the provisions of this Contract.
- "Original Term" means the period from the Commencement Date until the end of the Budget Year of Obligor.
- "Partial Prepayment Date" means the first Contract Payment date that occurs on or after the earlier of (a) the twenty-four month (24) anniversary of the Commencement Date or (b) the date on which Obligor has accepted all the Equipment and all amounts have been disbursed from the Vendor Payable Account to pay for the Equipment.
- "Purchase Price" means the total cost of the Equipment, including all delivery charges, installation charges, legal fees, financing costs, recording and filing fees and other costs necessary to vest full, clear legal title to the Equipment in Obligor, subject to the security interest granted to and retained by Obligee as set forth in this Contract, and otherwise incurred in connection with the financing of this Equipment.
- "Renewal Term" means the annual term which begins at the end of the Original Term and which is simultaneous with Obligor's Budget Year and each succeeding Budget Year for the number of Budget Years necessary to comprise the Contract Term.
- "State" means the state which Obligor is located.
- "Surplus Amount" means any amount on deposit in the Vendor Payable Account on the Partial Prepayment Date.
- "Vendor Payable Account" means the separate account of that name established pursuant to Section 11 of this Contract.

Obligor Warranties

Section 2.01 Obligor represents, warrants and covenants as follows for the benefit of Obligee or its assignees:

- (a) Obligor is an "issuer of tax exempt obligations" because Obligor is the State or a political subdivision of the State within the meaning of Section 103(a) of the Internal Revenue Code of 1986, as amended, (the "Code") or because Obligor is a constituted authority or district authorized to issue obligations on behalf of the State or political subdivision of the State within the meaning of Treasury Regulation 1.103-1(b), or a qualified volunteer fire company within the meaning of section 150(e)(1) of the Code.
- (b) Obligor has complied with any requirement for a referendum and/or competitive bidding.
- (c) Obligor has complied with all statutory laws and regulations that may be applicable to the execution of this Contract; Obligor, and its officer executing this Contract, are authorized under the Constitution and laws of the State to enter into this Contract and have used and followed all proper procedures of its governing body in executing and delivering this Contract. The officer of Obligor executing this Contract has the authority to execute and deliver this Contract. This Contract constitutes a legal, valid, binding and enforceable obligation of the Obligor in accordance with its terms.
- (d) Obligor shall use the Equipment only for essential, traditional government purposes.
- (e) Should the IRS disallow the tax-exempt status of the interest portion of the Contract Payments as a result of the failure of the Obligor to use the Equipment for governmental purposes, or should the Obligor cease to be an issuer of tax exempt obligations, or should the obligation of Obligor created under this Contract cease to be a tax exempt obligation for any reason, then Obligor shall be required to pay additional sums to the Obligee or its assignees so as to bring the after tax yield on this Contract to the same level as the Obligee or its assignees would attain if the transaction continued to be tax-exempt.
- (f) Obligor has never non-appropriated funds under a contract similar to this Contract.
- (g) Obligor will submit to the Secretary of the Treasury an information reporting statement as required by the Code.
- (h) Upon request by Obligee, Obligor will provide Obligee with current financial statements, reports, budgets or other relevant fiscal information.
- (i) Obligor shall retain the Equipment free of any hazardous substances as defined in the Comprehensive Environmental Response, Compensation and Liability Act, 42 U.S.C. 9601 et. seq. as amended and supplemented.
- (j) Obligor hereby warrants the General Fund of the Obligor is the primary source of funds or a backup source of funds from which the Contract Payments will be made.
- (k) Obligor presently intends to continue this Contract for the Original Term and all Renewal Terms as set forth on Exhibit B hereto. The official of Obligor responsible for budget preparation will include in the budget request for each Budget Year the Contract Payments to become due in such Budget Year, and will use all reasonable and lawful means available to secure the appropriation of money for such Budget Year sufficient to pay the Contract Payments coming due therein. Obligor reasonably believes that moneys can and will lawfully be appropriated and made available for this purpose.
- (l) Obligor has selected both the Equipment and the vendor(s) from whom the Equipment is to be purchased upon its own judgment and without reliance on any manufacturer, merchant, vendor or distributor, or agent thereof, of such equipment to the public.
- (m) Obligor owns the Equipment and any additional collateral free and clear of any liens, and Obligor has not and will not, during the Contract Term, create, permit, incur or assume any levies, liens or encumbrances of any kind with respect to the Equipment or any additional collateral except those created by this Contract.
- (n) Obligor warrants, as applicable, the purchase of any telecommunications and video surveillance services or equipment financed hereunder complies with 2 CFR § 200.216 and 2 CFR § 200.471.
- (o) Obligor warrants that it understands and has complied with 2 CFR § 200.322 in relation to domestic preferences for procurements, as applicable.

Section 2.02 Escrow Agreement. In the event both Obligees and Obligor mutually agree to utilize an Escrow Account, then immediately following the execution and delivery of this Contract, Obligees and Obligor agree to execute and deliver and to cause Escrow Agent to execute and deliver the Escrow Agreement. This Contract shall take effect only upon execution and delivery of the Escrow Agreement by the parties thereto. Obligees shall deposit or cause to be deposited with the Escrow Agent for credit to the Equipment Acquisition Fund the sum of \$N/A, which shall be held, invested and disbursed in accordance with the Escrow Agreement.

Acquisition of Equipment, Contract Payments and the Purchase Option Price

Section 3.01 Acquisition and Acceptance. Obligor shall be solely responsible for the ordering of the Equipment and for the delivery and installation of the Equipment. The Payment Request and Equipment Acceptance Form must be signed by the same authorized individual(s) who signed the Signature Card, Exhibit G. By making a Contract Payment after its receipt of the Equipment pursuant to this Contract, Obligor shall be deemed to have accepted the Equipment on the date of such Contract Payment for purposes of this Contract. All Contract Payments paid prior to delivery of the Payment Request and Equipment Acceptance Form shall be credited to Contract Payments as they become due as shown on the Contract Payment Schedule attached as Exhibit B hereto.

Section 3.02 Contract Payments. Obligor shall pay Contract Payments exclusively to Obligees or its assignees in lawful, legally available money of the United States of America. The Contract Payments shall be sent to the location specified by the Obligees or its assignees. The Contract Payments shall constitute a current expense of the Obligor and shall not constitute an indebtedness of the Obligor. The Contract Payments, payable without notice or demand, are due as set forth on Exhibit B. Obligees shall have the option to charge interest at the highest lawful rate on any Contract Payment received later than the due date for the number of days that the Contract Payment(s) were late, plus any additional accrual on the outstanding balance for the number of days that the Contract Payment(s) were late. Obligees shall also have the option, on monthly payments only, to charge a late fee of up to 10% of the monthly Contract Payment that is past due. Furthermore, Obligor agrees to pay any fees associated with the use of a payment system other than check, wire transfer, or ACH. Once all amounts due Obligees hereunder have been received, Obligees will release any and all of its rights, title and interest in the Equipment.

Section 3.03 CONTRACT PAYMENTS UNCONDITIONAL. Except as provided under Section 4.01, THE OBLIGATIONS OF OBLIGOR TO MAKE CONTRACT PAYMENTS AND TO PERFORM AND OBSERVE THE OTHER COVENANTS CONTAINED IN THIS CONTRACT SHALL BE ABSOLUTE AND UNCONDITIONAL IN ALL EVENTS WITHOUT ABATEMENT, DIMINUTION, DEDUCTION, SET-OFF, OR SUBJECT TO DEFENSE OR COUNTERCLAIM.

Section 3.04 Purchase Option Price. Upon thirty (30) days written notice, Obligor shall have the option to pay, in addition to the Contract Payment, the corresponding Purchase Option Price which is listed on the same line on Exhibit B. This option is only available to the Obligor on the Contract Payment date and no partial prepayments are allowed. If Obligor chooses this option and pays the Purchase Option Price to Obligees then Obligees will transfer any and all of its rights, title and interest in the Equipment to Obligor.

Section 3.05 Contract Term. The Contract Term shall be the Original Term and all Renewal Terms until all the Contract Payments are paid as set forth on Exhibit B except as provided under Section 4.01 and Section 9.01 below. If, after the end of the budgeting process which occurs at the end of the Original Term or any Renewal Term, Obligor has not non-appropriated as provided for in this Contract then the Contract Term shall be extended into the next Renewal Term and the Obligor shall be obligated to make all the Contract Payments that come due during such Renewal Term.

Section 3.06 Disclaimer of Warranties. OBLIGEE MAKES NO WARRANTY OR REPRESENTATION, EITHER EXPRESS OR IMPLIED, AS TO THE VALUE, DESIGN, CONDITION, MERCHANTABILITY, FITNESS FOR PARTICULAR PURPOSE OR ANY OTHER WARRANTY WITH RESPECT TO THE EQUIPMENT. OBLIGEE IS NOT A MANUFACTURER, SELLER, VENDOR OR DISTRIBUTOR, OR AGENT THEREOF, OF SUCH EQUIPMENT; NOR IS OBLIGEE A MERCHANT OR IN THE BUSINESS OF DISTRIBUTING SUCH EQUIPMENT TO THE PUBLIC. OBLIGEE SHALL NOT BE LIABLE FOR ANY INCIDENTAL, INDIRECT, SPECIAL OR CONSEQUENTIAL DAMAGE ARISING OUT OF THE INSTALLATION, OPERATION, POSSESSION, STORAGE OR USE OF THE EQUIPMENT BY OBLIGOR.

Non-Appropriation

Section 4.01 Non-Appropriation. In accordance with Minn. Stat. Ann. Section 465.71 Obligor has the right to terminate this Contract at the end of any Budget Year during the Contract Term by not appropriating the funds to make the Contract Payments for the next Renewal Term. Such non-appropriation shall be evidenced by the passage of an ordinance or resolution by the governing body of Obligor specifically prohibiting Obligor from performing its obligations under this Contract and from using any moneys to pay the Contract Payments due under this Contract for a designated Budget Year and all subsequent Budget Years. If Obligor non-appropriates, then all obligations of the Obligor under this Contract regarding Contract Payments for all remaining Renewal Terms shall be terminated at the end of the then current Original Term or Renewal Term without penalty or liability to the Obligor of any kind provided that if Obligor has not delivered possession of the Equipment to Obligees as provided herein and conveyed to Obligees or released its interest in the Equipment by the end of the last Budget Year for which Contract Payments were paid, the termination shall nevertheless be effective but Obligor shall be responsible for the payment of damages in an amount equal to the amount of the Contract Payments thereafter coming due under Exhibit B which are attributable to the number of days after such Budget Year during which Obligor fails to take such actions and for any other loss suffered by Obligees as a result of Obligor's failure to take such actions as required. Obligor shall immediately notify the Obligees as soon as the decision to non-appropriate is made. If such non-appropriation occurs, then Obligor shall deliver the Equipment to Obligees as provided below in Section 9.04. Obligor shall be liable for all damage to the Equipment other than normal wear and tear. If Obligor fails to deliver the Equipment to Obligees, then Obligees may enter the premises where the Equipment is located and take possession of the Equipment and charge Obligor for costs incurred.

Insurance, Damage, Insufficiency of Proceeds

Section 5.01 Insurance. Obligor shall maintain both property insurance and liability insurance at its own expense with respect to the Equipment. Obligor shall be solely responsible for selecting the insurer(s) and for making all premium payments and ensuring that all policies are continuously kept in effect during the period when Obligor is required to make Contract Payments. Obligor shall provide Obligees with a certificate of Insurance which lists the Obligees and/or assigns as a loss payee and an additional insured on the policies with respect to the Equipment.

- (a) Obligor shall insure the Equipment against any loss or damage by fire and all other risks covered by the standard extended coverage endorsement then in use in the State and any other risks reasonably required by Obligees in an amount at least equal to the then applicable Purchase Option Price of the Equipment. Alternatively, Obligor may insure the Equipment under a blanket insurance policy or policies.
- (b) The liability insurance shall insure Obligees from liability and property damage in any form and amount satisfactory to Obligees.
- (c) Obligor may self-insure against the casualty risks and liability risks described above. If Obligor chooses this option, Obligor must furnish Obligees with a certificate and/or other documents which evidences such coverage.
- (d) All insurance policies issued or affected by this Section shall be so written or endorsed such that the Obligees and its assignees are named additional insureds and loss payees and that all losses are payable to Obligor and Obligees or its assignees as their interests may appear. Each policy issued or affected by this Section shall contain a provision that the insurance company shall not cancel or materially modify the policy without first giving thirty (30) days advance notice to Obligees or its assignees. Obligor shall furnish to Obligees certificates evidencing such coverage throughout the Contract Term.

Section 5.02 Damage to or Destruction of Equipment. Obligor assumes the risk of loss or damage to the Equipment. If the Equipment or any portion thereof is lost, stolen, damaged, or destroyed by fire or other casualty, Obligor will immediately report all such losses to all possible insurers and take the proper procedures to obtain all insurance proceeds. At the option of Obligees, Obligor shall either (1) apply the Net Proceeds to replace, repair or restore the Equipment or (2) apply the Net Proceeds to the applicable Purchase Option Price. For purposes of this Section and Section 5.03, the term Net Proceeds shall mean the amount of insurance proceeds collected from all applicable insurance policies after deducting all expenses incurred in the collection thereof.

Section 5.03 Insufficiency of Net Proceeds. If there are no Net Proceeds for whatever reason or if the Net Proceeds are insufficient to pay in full the cost of any replacement, repair, restoration, modification or improvement of the Equipment, then Obligor shall, at the option of Obligees, either (1) complete such replacement, repair, restoration, modification or improvement and pay any costs thereof in excess of the amount of the Net Proceeds or (2) apply the Net Proceeds to the Purchase Option Price and pay the deficiency, if any, to the Obligees.

Section 5.04 Obligor Negligence. Obligor assumes all risks and liabilities, whether or not covered by insurance, for loss or damage to the Equipment and for injury to or death of any person or damage to any property whether such injury or death be with respect to agents or employees of Obligor or of third parties, and whether such property damage be to Obligor's property or the property of others (including, without limitation, liabilities for loss or damage related to the release or threatened release of hazardous substances under the Comprehensive Environmental Response, Compensation and Liability Act, the Resource Conservation and Recovery Act or similar or successor law or any State or local equivalent now existing or hereinafter enacted which in any manner arise out of or are incident to any possession, use, operation, condition or storage of any Equipment by Obligor), which is proximately caused by the negligent conduct of Obligor, its officers, employees and agents.

Section 5.05 Reimbursement. Obligor hereby assumes responsibility for and agrees to reimburse Obligees for all liabilities, obligations, losses, damages, penalties, claims, actions, costs and expenses (including reasonable attorneys' fees) of whatsoever kind and nature, imposed on, incurred by or asserted against Obligees that in any way relate to or arise out of a claim, suit or proceeding, based in whole or in part upon the negligent conduct of Obligor, its officers, employees and agents, or arose out of installation, operation, possession, storage or use of any item of the Equipment, to the maximum extent permitted by law.

Title and Security Interest

Section 6.01 Title. Title to the Equipment shall vest in Obligor when Obligor acquires and accepts the Equipment. Title to the Equipment will automatically transfer to the Obligee in the event Obligor non-appropriates under Section 4.01 or in the event Obligor defaults under Section 9.01. In such event, Obligor shall execute and deliver to Obligee such documents as Obligee may request to evidence the passage of legal title to the Equipment to Obligee. For purposes of satisfying Minn. Stat. Ann. Section 465.71, Obligor hereby assigns the title to the Equipment to the Obligee as security for the purchase price. Once Obligee has received all Contract Payments and other amounts that may be owed or once Obligee receives the applicable Purchase Option Price, Obligee will be deemed to have assigned the title to the Equipment for purposes of the above referenced statute back to Obligor.

Section 6.02 Security Interest. To secure the payment of all Obligor's obligations under this Contract, as well as all other obligations, debts and liabilities, plus interest thereon, whether now existing or subsequently created, Obligor hereby grants to Obligee a security interest under the Uniform Commercial Code constituting a first lien on the Equipment described more fully on Exhibit A. Furthermore, Obligor agrees that any other collateral securing any other obligation(s) to Obligee, whether offered prior to or subsequent hereto, also secures this obligation. The security interest established by this section includes not only all additions, attachments, repairs and replacements to the Equipment but also all proceeds therefrom. Obligor authorizes Obligee to prepare and record any Financing Statement required under the Uniform Commercial Code to perfect the security interest created hereunder. Obligor agrees that any Equipment listed on Exhibit A is and will remain personal property and will not be considered a fixture even if attached to real property.

Assignment

Section 7.01 Assignment by Obligee. All of Obligee's rights, title and/or interest in and to this Contract may be assigned and reassigned in whole or in part to one or more assignees or sub-assignees by Obligee at any time without the consent of Obligor. No such assignment shall be effective as against Obligor until the assignor shall have filed with Obligor written notice of assignment identifying the assignee. Obligor shall pay all Contract Payments due hereunder relating to such Equipment to or at the direction of Obligee or the assignee named in the notice of assignment. Obligor shall keep a complete and accurate record of all such assignments.

Section 7.02 Assignment by Obligor. None of Obligor's right, title and interest under this Contract and in the Equipment may be assigned by Obligor unless Obligee approves of such assignment in writing before such assignment occurs and only after Obligor first obtains an opinion from nationally recognized counsel stating that such assignment will not jeopardize the tax-exempt status of the obligation.

Maintenance of Equipment

Section 8.01 Equipment. Obligor shall keep the Equipment in good repair and working order, and as required by manufacturer's and warranty specifications. If Equipment consists of copiers, Obligor is required to enter into a copier maintenance/service agreement. Obligee shall have no obligation to inspect, test, service, maintain, repair or make improvements or additions to the Equipment under any circumstances. Obligor will be liable for all damage to the Equipment, other than normal wear and tear, caused by Obligor, its employees or its agents. Obligor shall pay for and obtain all permits, licenses and taxes related to the ownership, installation, operation, possession, storage or use of the Equipment. If the Equipment includes any titled vehicle(s), then Obligor is responsible for obtaining such title(s) from the State and also for ensuring that Obligee is listed as First Lienholder on all of the title(s). Obligor shall not use the Equipment to haul, convey or transport hazardous waste as defined in the Resource Conservation and Recovery Act, 42 U.S.C. 6901 et. seq. Obligor agrees that Obligee or its Assignee may execute any additional documents including financing statements, affidavits, notices, and similar instruments, for and on behalf of Obligor which Obligee deems necessary or appropriate to protect Obligee's interest in the Equipment and in this Contract. Obligor shall allow Obligee to examine and inspect the Equipment at all reasonable times.

Default

Section 9.01 Events of Default defined. The following events shall constitute an "Event of Default" under this Contract:

- (a) Failure by Obligor to pay any Contract Payment listed on Exhibit B for fifteen (15) days after such payment is due according to the Payment Date listed on Exhibit B.
- (b) Failure to pay any other payment required to be paid under this Contract at the time specified herein and a continuation of said failure for a period of fifteen (15) days after written notice by Obligee that such payment must be made. If Obligor continues to fail to pay any payment after such period, then Obligee may, but will not be obligated to, make such payments and charge Obligor for all costs incurred plus interest at the highest lawful rate.
- (c) Failure by Obligor to observe and perform any warranty, covenant, condition, promise or duty under this Contract for a period of thirty (30) days after written notice specifying such failure is given to Obligor by Obligee, unless Obligee agrees in writing to an extension of time. Obligee will not unreasonably withhold its consent to an extension of time if corrective action is instituted by Obligor. Subsection (c) does not apply to Contract Payments and other payments discussed above.
- (d) Any statement, material omission, representation or warranty made by Obligor in or pursuant to this Contract which proves to be false, incorrect or misleading on the date when made regardless of Obligor's intent and which materially adversely affects the rights or security of Obligee under this Contract.
- (e) Any provision of this Contract which ceases to be valid for whatever reason and the loss of such provision would materially adversely affect the rights or security of Obligee.
- (f) Except as provided in Section 4.01 above, Obligor admits in writing its inability to pay its obligations.
- (g) Obligor defaults on one or more of its other obligations.
- (h) Obligor becomes insolvent, is unable to pay its debts as they become due, makes an assignment for the benefit of creditors, applies for or consents to the appointment of a receiver, trustee, conservator, custodian, or liquidator of Obligor, or all or substantially all of its assets, or a petition for relief is filed by Obligor under federal bankruptcy, insolvency or similar laws, or is filed against Obligor and is not dismissed within thirty (30) days thereafter.

Section 9.02 Remedies on Default. Whenever any Event of Default exists, Obligee shall have the right to take one or any combination of the following remedial steps:

- (a) With or without terminating this Contract, Obligee may declare all Contract Payments and other amounts payable by Obligor hereunder to the end of the then current Budget Year to be immediately due and payable.
- (b) With or without terminating this Contract, Obligee may require Obligor at Obligor's expense to redeliver any or all of the Equipment and any additional collateral to Obligee as provided below in Section 9.04. Such delivery shall take place within fifteen (15) days after the Event of Default occurs. If Obligor fails to deliver the Equipment and any additional collateral, Obligee may enter the premises where the Equipment and any additional collateral is located and take possession of the Equipment and any additional collateral and charge Obligor for costs incurred. Notwithstanding that Obligee has taken possession of the Equipment and any additional collateral, Obligor shall still be obligated to pay the remaining Contract Payments due up until the end of the then current Original Term or Renewal Term. Obligor will be liable for any damage to the Equipment and any additional collateral caused by Obligor or its employees or agents.
- (c) Obligee may take whatever action at law or in equity that may appear necessary or desirable to enforce its rights. Obligor shall be responsible to Obligee for all costs incurred by Obligee in the enforcement of its rights under this Contract including, but not limited to, reasonable attorney fees.

Section 9.03 No Remedy Exclusive. No remedy herein conferred upon or reserved to Obligee is intended to be exclusive and every such remedy shall be cumulative and shall be in addition to every other remedy given under this Contract now or hereafter existing at law or in equity. No delay or omission to exercise any right or power accruing upon any default shall impair any such right or shall be construed to be a waiver thereof.

Section 9.04 Return of Equipment and Storage.

- (a) Surrender: The Obligor shall, at its own expense, surrender the Equipment, any additional collateral and all required documentation to evidence transfer of title from Obligor to the Obligee in the event of a default or a non-appropriation by delivering the Equipment and any additional collateral to the Obligee to a location accessible by common carrier and designated by Obligee. In the case that any of the Equipment and any additional collateral consists of software, Obligor shall destroy all intangible items constituting such software and shall deliver to Obligee all tangible items constituting such software. At Obligee's request, Obligor shall also certify in a form acceptable to Obligee that Obligor has complied with the above software return provisions and that they will immediately cease using the software and that they shall permit Obligee and/or the vendor of the software to inspect Obligor's locations to verify compliance with the terms hereto.

(b) **Delivery:** The Equipment and any additional collateral shall be delivered to the location designated by the Oblige by a common carrier unless the Oblige agrees in writing that a common carrier is not needed. When the Equipment and any additional collateral is delivered into the custody of a common carrier, the Obligor shall arrange for the shipping of the item and its insurance in transit in accordance with the Oblige's instructions and at the Obligor's sole expense. Obligor at its expense shall completely sever and disconnect the Equipment and any additional collateral or its component parts from the Obligor's property all without liability to the Oblige. Obligor shall pack or crate the Equipment and any additional collateral and all of the component parts of the Equipment and any additional collateral carefully and in accordance with any recommendations of the manufacturer. The Obligor shall deliver to the Oblige the plans, specifications, operation manuals or other warranties and documents furnished by the manufacturer or vendor on the Equipment and any additional collateral and such other documents in the Obligor's possession relating to the maintenance and methods of operation of such Equipment and any additional collateral.

(c) **Condition:** When the Equipment is surrendered to the Oblige it shall be in the condition and repair required to be maintained under this Contract. It will also meet all legal regulatory conditions necessary for the Oblige to sell or lease it to a third party and be free of all liens. If Oblige reasonably determines that the Equipment or an item of the Equipment, once it is returned, is not in the condition required hereby, Oblige may cause the repair, service, upgrade, modification or overhaul of the Equipment or an item of the Equipment to achieve such condition and upon demand, Obligor shall promptly reimburse Oblige for all amounts reasonably expended in connection with the foregoing.

(d) **Storage:** Upon written request by the Oblige, the Obligor shall provide free storage for the Equipment and any additional collateral for a period not to exceed 60 days after the expiration of the Contract Term before returning it to the Oblige. The Obligor shall arrange for the insurance described to continue in full force and effect with respect to such item during its storage period and the Oblige shall reimburse the Obligor on demand for the incremental premium cost of providing such insurance.

Miscellaneous

Section 10.01 Notices. All notices shall be sufficiently given and shall be deemed given when delivered or mailed by registered mail, postage prepaid, to the parties at their respective places of business as first set forth herein or as the parties shall designate hereafter in writing.

Section 10.02 Binding Effect. Obligor acknowledges this Contract is not binding upon the Oblige or its assignees unless the Conditions to Funding listed on the Documentation Instructions have been met to Oblige's satisfaction, and Oblige has executed the Contract. Thereafter, this Contract shall inure to the benefit of and shall be binding upon Oblige and Obligor and their respective successors and assigns.

Section 10.03 Severability. In the event any provision of this Contract shall be held invalid or unenforceable by any court of competent jurisdiction, such holding shall not invalidate or render unenforceable any other provision hereof.

Section 10.04 Amendments, Addenda, Changes or Modifications. This Contract may be amended, added to, changed or modified by written agreement duly executed by Oblige and Obligor. Furthermore, Oblige reserves the right to directly charge or amortize into the remaining balance due from Obligor, a reasonable fee, to be determined at that time, as compensation to Oblige for the additional administrative expense resulting from such amendment, addenda, change or modification requested by Obligor.

Section 10.05 Execution in Counterparts and Electronic Signatures. This Contract may be simultaneously executed in several counterparts, including electronically, each of which shall be an original and all of which shall constitute one and the same instrument.

Section 10.06 Captions. The captions or headings in this Contract do not define, limit or describe the scope or intent of any provisions or sections of this Contract.

Section 10.07 Master Contract. This Contract can be utilized as a Master Contract. This means that the Oblige and the Obligor may agree to the financing of additional Equipment under this Contract at some point in the future by executing one or more Additional Schedules to Exhibit A and Exhibit B, as well as other exhibits or documents that may be required by Oblige. Additional Schedules will be consecutively numbered on each of the exhibits which make up the Additional Schedule and all the terms and conditions of the Contract shall govern each Additional Schedule.

Section 10.08 Entire Writing. This Contract constitutes the entire writing between Oblige and Obligor. No waiver, consent, modification or change of terms of this Contract shall bind either party unless in writing and signed by both parties, and then such waiver, consent, modification or change shall be effective only in the specific instance and for the specific purpose given. There are no understandings, agreements, representations, conditions, or warranties, express or implied, which are not specified herein regarding this Contract, the Equipment or any additional collateral, financed hereunder. Any terms and conditions of any purchase order or other documents submitted by Obligor in connection with this Contract which are in addition to or inconsistent with the terms and conditions of this Contract will not be binding on Oblige and will not apply to this Contract.

Vendor Payable Account

Section 11.01 Establishment of Vendor Payable Account. On the date that the Oblige executed this Contract, which is on or after the date that the Obligor executes this Contract, Oblige agrees to (i) make available to Obligor an amount sufficient to pay the total Purchase Price for the Equipment by establishing a separate, non-interest bearing account (the "Vendor Payable Account"), as agent for Obligor's account, with a financial institution that Oblige selects that is acceptable to Obligor (including Oblige or any of its affiliates) and (ii) to deposit an amount equal to such Purchase Price as reflected on Exhibit B in the Vendor Payable Account. Obligor hereby further agrees to make the representations, warranties and covenants relating to the Vendor Payable Account as set forth in Exhibit C attached hereto. Upon Obligor's delivery to Oblige of a Payment Request and Equipment Acceptance Form in the form set forth in Exhibit F attached hereto, Obligor authorizes Oblige to withdraw funds from the Vendor Payable Account from time to time to pay the Purchase Price, or a portion thereof, for each item of Equipment as it is delivered to Obligor. The Payment Request and Equipment Acceptance Form must be signed by an authorized individual acting on behalf of Obligor. The authorized individual or individuals designated by the Obligor must sign the Signature Card which will be kept in the possession of the Oblige.

Section 11.02 Down Payment. Prior to the disbursement of any funds from the Vendor Payable Account, the Obligor must either (1) deposit all the down payment funds that the Obligor has committed towards the purchase of the Equipment into the Vendor Payable Account or (2) Obligor must provide written verification to the satisfaction of the Oblige that all the down payment funds Obligor has committed towards the purchase of the Equipment have already been spent or are simultaneously being spent with the funds requested from the initial Payment Request and Equipment Acceptance Form. For purposes of this Section, the down payment funds committed towards the Equipment from the Obligor are the down payment funds that were represented to the Oblige at the time this transaction was submitted for credit approval by the Obligor to the Oblige.

Section 11.03 Disbursement upon Non-Appropriation or Default. If an event of non-appropriation or default occurs prior to the Partial Prepayment Date, the amount then on deposit in the Vendor Payable Account shall be retained by the Oblige and Obligor will have no interest therein.

Section 11.04 Surplus Amount. Any Surplus Amount then on deposit in the Vendor Payable Account on the Partial Prepayment Date shall, at Oblige's sole discretion, either a) be returned to Obligor, or b) be applied to pay on such Partial Prepayment Date a portion of the Purchase Option Price then applicable.

Section 11.05 Recalculation of Contract Payments. Should Oblige decide to apply the Surplus Amount to the then applicable Purchase Option Price as provided in Section 11.04 above, each Contract Payment thereafter shall be reduced by an amount calculated by Oblige based upon a fraction the numerator of which is the Surplus Amount and the denominator of which is the Purchase Option Price on such Partial Prepayment Date. Within 15 days after such Partial Prepayment Date, Oblige shall provide to Obligor a revised Exhibit B to this Contract, which shall take into account such payment of a portion of the Purchase Option Price thereafter and shall be and become thereafter Exhibit B to this Contract. Notwithstanding any other provision of this Section 11, this Contract shall remain in full force and effect with respect to all or the portion of the Equipment accepted by Obligor as provided in this Contract, and the portion of the principal component of Contract Payments remaining unpaid after the Partial Prepayment Date plus accrued interest thereon shall remain payable in accordance with the terms of this Contract, including revised Exhibit B hereto which shall be binding and conclusive upon Oblige and Obligor.

Obligee and Obligor have caused this Contract to be executed in their names by their duly authorized representatives listed below.

City of North Branch, Minnesota

KS StateBank

Signature

Matthew Hill, City Administrator

Printed Name and Title

Signature

Jaymie Paavola-Luckert, Vice President

Printed Name and Title

EXHIBIT A

DESCRIPTION OF EQUIPMENT

RE: Government Obligation Contract dated as of January 26, 2026, between KS StateBank (Obligee) and City of North Branch, Minnesota (Obligor)

Below is a detailed description of all the items of Equipment including quantity, model number and serial number where applicable:

Three (3) 2026 Ford Police Interceptor Vehicles with Upfitting and One (1) 2026 Ford F150 Responder with Upfitting

Physical Address of Equipment after Delivery: 6408 Elm St, North Branch, MN 55056

PAYMENT SCHEDULE

RE: Government Obligation Contract dated as of January 26, 2026, between KS StateBank (Obligee) and City of North Branch, Minnesota (Obligor)

Date of First Payment	At Closing
Original Balance	\$299,908.01
Total Number of Payments	Five (5)
Number of Payments Per Year	One (1)

Pmt No.	Due Date	Contract Payment	Applied to Interest	Applied to Principal	*Purchase Option Price
1	At Closing	\$66,510.30	\$0.00	\$66,510.30	\$235,240.85
2	26-Jan-27	\$66,510.30	\$12,720.16	\$53,790.14	\$180,751.36
3	26-Jan-28	\$66,510.30	\$9,788.60	\$56,721.70	\$123,477.45
4	26-Jan-29	\$66,510.30	\$6,697.27	\$59,813.03	\$63,276.85
5	26-Jan-30	\$66,510.30	\$3,437.46	\$63,072.84	\$0.00

City of North Branch, Minnesota

Signature

Matthew Hill, City Administrator

Printed Name and Title

*Assumes all Contract Payments due to date are paid

EXHIBIT C

**ACCEPTANCE OF OBLIGATION
TO COMMENCE CONTRACT PAYMENTS UNDER EXHIBIT B**

RE: Government Obligation Contract dated as of January 26, 2026, between KS StateBank (Obligee) and City of North Branch, Minnesota (Obligor)

I, the undersigned, hereby certify that I am a duly qualified representative of Obligor and that I have been given the authority by the governing body of Obligor to sign this Acceptance of Obligation to commence Contract Payments with respect to the above referenced Contract. I hereby certify that:

1. The Equipment described on Exhibit A has not been delivered, installed or available for use as of the Commencement date of this Contract.
2. Obligor acknowledges that Obligee has agreed to deposit into a Vendor Payable Account an amount sufficient to pay the total purchase price (the "Purchase Price") for the Equipment so identified in such Exhibit A;
3. The principal amount of the Contract Payments in the Exhibit B accurately reflects the Purchase Price;
4. Obligor agrees to execute a Payment Request and Equipment Acceptance Form authorizing payment of the Purchase Price, or a portion thereof, for each withdrawal of funds from the Vendor Payable Account.

Notwithstanding that the Equipment has not been delivered to or accepted by Obligor on the date of execution of the Contract, Obligor hereby warrants that:

- (a) Obligor's obligation to commence Contract Payments as set forth in Exhibit B is absolute and unconditional as of the Commencement Date and on each date set forth in Exhibit B thereafter, subject to the terms and conditions of the Contract;
- (b) immediately upon delivery and acceptance of all the Equipment, Obligor will notify Obligee of Obligor's final acceptance of the Equipment by delivering to Obligee the "Payment Request and Equipment Acceptance Form" in the form set forth in Exhibit F attached to the Contract;
- (c) in the event that any Surplus Amount is on deposit in the Vendor Payable Account when an event of non-appropriation or default under the Contract occurs, then those amounts shall be applied as provided in Section 11 of the Contract;
- (d) regardless of whether Obligor delivers a final Payment Request and Equipment Acceptance Form, all Contract Payments paid prior to delivery of all the Equipment shall be credited to Contract Payments as they become due under the Contract as set forth in Exhibit B.

City of North Branch, Minnesota

Signature

Matthew Hill, City Administrator

Printed Name and Title

EXHIBIT D

OBLIGOR RESOLUTION

RE: Government Obligation Contract dated as of January 26, 2026, between KS StateBank (Obligee) and City of North Branch, Minnesota (Obligor)

At a duly called meeting of the Governing Body of the Obligor (as defined in the Contract) held on _____ the following resolution was introduced and adopted:

BE IT RESOLVED by the Governing Body of Obligor as follows:

1. **Determination of Need.** The Governing Body of Obligor has determined that a true and very real need exists for the acquisition of the Equipment described on Exhibit A of the Government Obligation Contract dated as of January 26, 2026, between City of North Branch, Minnesota (Obligor) and KS StateBank (Obligee).

2. **Approval and Authorization.** The Governing Body of Obligor has determined that the Contract, substantially in the form presented to this meeting, is in the best interests of the Obligor for the acquisition of such Equipment, and the Governing Body hereby approves the entering into of the Contract by the Obligor and hereby designates and authorizes the following person(s) to execute and deliver the Contract on Obligor's behalf with such changes thereto as such person(s) deem(s) appropriate, and any related documents, including any Escrow Agreement, necessary to the consummation of the transaction contemplated by the Contract.

Authorized Individual(s): Matthew Hill, City Administrator

(Typed or Printed Name and Title of Individual(s) authorized to execute the Contract)

3. **Adoption of Resolution.** The signatures below from the designated individuals from the Governing Body of the Obligor evidence the adoption by the Governing Body of this Resolution.

Signature: _____
(Signature of Board Chairman or other authorized member of the Obligor's Governing Body)

Printed Name & Title: Matthew Hill, City Administrator

(Printed Name and Title of individual who signed directly above)

Attested By: _____
(Signature of Obligor's Board Secretary or Board Clerk)

Printed Name & Title: Dan Meyer, Chief of Police

(Printed Name of individual who signed directly above)

EXHIBIT E

OFFICER'S CERTIFICATE

RE: Government Obligation Contract dated as of January 26, 2026, between KS StateBank (Obligee) and City of North Branch, Minnesota (Obligor)

I, the undersigned, hereby certify that I am a duly qualified representative of Obligor and that I have been given the authority by the governing body of Obligor to sign this Officer's Certificate with respect to the above referenced Contract. I hereby certify that:

1. Obligor has appropriated and/or taken other lawful actions necessary to provide moneys sufficient to pay all Contract Payments required to be paid under the Contract during the current Budget Year of Obligor, and such moneys will be applied in payment of all Contract Payments due and payable during such current Budget Year.
2. Obligor has obtained insurance coverage as required under the Contract from an insurer qualified to do business in the State.
3. No event or condition that constitutes or would constitute an Event of Default exists as of the date hereof.
4. The governing body of Obligor has approved the authorization, execution and delivery of this Contract on its behalf by the authorized representative of Obligor who signed the Contract.
5. Please list the Source of Funds (Fund Item in Budget) for the Contract Payments that come due under Exhibit B of this Contract.

Source of Funds: General Fund

By signing below, Obligor hereby authorizes the General Fund of the Obligor as a backup source of funds from which the Contract Payments can be made.

City of North Branch, Minnesota

Signature

Matthew Hill, City Administrator

Printed Name and Title

EXHIBIT F

PAYMENT REQUEST AND EQUIPMENT ACCEPTANCE FORM

RE: Government Obligation Contract dated as of January 26, 2026, between KS StateBank (Obligee) and City of North Branch, Minnesota (Obligor)

In accordance with Section 11.01, by executing this Payment Request and Equipment Acceptance Form the Obligor hereby represents that the Payee or Payees listed below who are requesting payment have delivered the Equipment or a portion of the Equipment or performed the services to the satisfaction of the Obligor and that the amounts requested below by the Payee or Payees are proportionate with the value of the Equipment delivered or services rendered by the Payee or Payees. The Obligor hereby represents and warrants for all purposes that:

1. Pursuant to the invoice attached hereto, the amount to be disbursed is \$ _____ and this amount is consistent with the Contract between Obligor and vendor.
2. Payment is to be made to: Payee: _____

3. The undersigned certifies that the following documents are attached to this Payment Request and Equipment Acceptance Form when there is a request for a release of funds from the Vendor Payable Account to pay for a portion, or all, of the Equipment: (1) Invoice from the vendor, (2) copy of the Contract between Obligor and vendor (if requested by the Obligee), (3) Insurance Certificate (if applicable), (4) front and back copy of the original MSO/Title listing KS StateBank and/or its assigns as the first lien holder (if applicable). By executing this Payment Request and Equipment Acceptance Form and attaching the documents as required above, the Obligor shall be deemed to have accepted this portion of the Equipment for all purposes under the Contract, including, without limitation, the obligation of Obligor to make the Contract Payments with respect thereto in a proportionate amount of the total Contract Payment.

4. No amount listed in this exhibit was included in any such exhibit previously submitted.
5. Each disbursement hereby requested has been incurred and is a proper charge against the Vendor Payable Account. No amount hereby requested to be disbursed will be paid to Obligor as reimbursement for any expenditure paid by Obligor more than 60 days prior to the date of execution and delivery of the Contract.
6. The Equipment referenced in the attached has been delivered, installed, inspected and tested as necessary and in accordance with Obligor's specifications and accepted for all purposes.
7. That Obligor is or will be the title owner to the Equipment referenced in the attached, and that in the event that any third party makes a claim to such title that Obligor will take all measures necessary to secure title including, without limitation, the appropriation of additional funds to secure title to such Equipment, or a portion thereof, and keep the Contract in full force and effect. Furthermore, Obligor has obtained insurance coverage as required under the Contract from an insurer qualified to do business in the State.
8. Obligor has appropriated and/or taken other lawful actions necessary to provide moneys sufficient to pay all Contract Payments required to be paid under the Contract during the current Budget Year of Obligor, and such moneys will be applied in payment of all Contract Payments due and payable during such current Budget Year.
9. No event or condition that constitutes or would constitute an Event of Default exists as of the date hereof.

I, the undersigned, hereby certify that I am a duly qualified representative of Obligor and that I have been given the authority by the governing body of Obligor to sign this Payment Request and Equipment Acceptance Form.

Please forward this document and any correspondence relating to vendor payment to:

Email muhrich@ksstate.bank
or
Fax (785) 587-4016

Please call (877) 587-4054 if you have any questions.

City of North Branch, Minnesota

Signature

Matthew Hill, City Administrator

Printed Name and Title

EXHIBIT G

SIGNATURE CARD

RE: Government Obligation Contract dated as of January 26, 2026, between KS StateBank (Obligee) and City of North Branch, Minnesota (Obligor)

The below signatures will be used for purposes of verifying the signature on a Payment Request and Equipment Acceptance Form prior to making payments from the Equipment Acquisition Fund or Vendor Payable Account. By signing below, the undersigned represents and warrants that they have received all appropriate authority from City of North Branch, Minnesota.

City of North Branch, Minnesota

Signature

Matthew Hill, City Administrator

Printed Name and Title

Signature of additional authorized individual (optional) of Obligor

Signature

Dan Meyer, Chief of Police

Printed Name and Title

EXHIBIT H

OBLIGOR ACKNOWLEDGEMENT

RE: Government Obligation Contract dated as of January 26, 2026, between KS StateBank (Obligee) and City of North Branch, Minnesota (Obligor)

Obligor hereby acknowledges that it has ordered or caused to be ordered the equipment that is the subject of the above-mentioned Contract.

Please complete the below information, attach another page if necessary.

Vendor Name: _____

Equipment: _____

Cost of Equipment: _____

Vendor Name: _____

Equipment: _____

Cost of Equipment: _____

Vendor Name: _____

Equipment: _____

Cost of Equipment: _____

Vendor Name: _____

Equipment: _____

Cost of Equipment: _____

Vendor Name: _____

Equipment: _____

Cost of Equipment: _____

Obligor will immediately notify Obligee if any of the information listed above is changed.

EXHIBIT I

BANK QUALIFIED CERTIFICATE

RE: Government Obligation Contract dated as of January 26, 2026, between KS StateBank (Obligee) and City of North Branch, Minnesota (Obligor)

Whereas, Obligor hereby represents that it is a "Bank Qualified" Issuer for the calendar year in which this Contract is executed by making the following designations with respect to Section 265 of the Internal Revenue Code of 1986, as amended (the "Code"). (A "Bank Qualified Issuer" is an issuer that issues less than ten million (\$10,000,000) dollars of tax-exempt obligations other than "private activity bonds" as defined in Section 141 of the Code, excluding certain "qualified 501(c)(3) bonds" as defined in Section 145 of the Code, during the calendar year).

Now, therefor, Obligor hereby designates this Contract as follows:

1. **Designation as Qualified Tax-Exempt Obligation.** Pursuant to Section 265(b)(3)(B)(i) of the Code, the Obligor hereby specifically designates the Contract as a "qualified tax-exempt obligation" for purposes of Section 265(b)(3) of the Code. In compliance with Section 265(b)(3)(D) of the Code, the Obligor hereby represents that the Obligor will not designate more than \$10,000,000 of obligations issued by the Obligor in the calendar year during which the Contract is executed and delivered as such "qualified tax-exempt obligations".

2. **Issuance Limitation.** In compliance with the requirements of Section 265(b)(3)(C) of the Code, the Obligor hereby represents that the Obligor (including all subordinate entities of the Obligor within the meaning of Section 265(b)(3)(E) of the Code) reasonably anticipates not to issue in the calendar year during which the Contract is executed and delivered, obligations bearing interest exempt from federal income taxation under Section 103 of the Code (other than "private activity bonds" as defined in Section 141 of the Code and excluding certain "qualified 501(c)(3) bonds" as defined in Section 145 of the Code) in an amount greater than \$10,000,000.

City of North Branch, Minnesota

Signature

Matthew Hill, City Administrator

Printed Name and Title

INSURANCE REQUIREMENTS

Pursuant to Article 5 of the Government Obligation Contract, you have agreed to provide us evidence of insurance covering the Equipment.

A Certificate of Insurance listing the information stated below should be sent to us no later than the date on which the equipment is delivered.

Insured:

City of North Branch, Minnesota
6408 Elm Street
North Branch, Minnesota 55056

Certificate Holder:

KS StateBank AOIA (and/or Its Assigns)
1010 Westloop Place
Manhattan, Kansas 66502-0069

1. Equipment Description

- * Three (3) 2026 Ford Police Interceptor Vehicles with Upfitting and One (1) 2026 Ford F150 Responder with Upfitting
- * Please include all applicable VIN's, serial numbers, etc.

2. Deductible

- * The deductible amounts on the insurance policy should not exceed \$25,000.00.

3. Physical Damage

- * All risk coverage to guarantee proceeds of at least \$299,908.01.

4. Liability

- * Minimum Combined Single Limit of \$1,000,000.00 on bodily injury and property damage.

5. Additional Insured and Loss Payee

- * KS StateBank AOIA (and/or Its Assigns) MUST be listed as additional insured and loss payee.

Please forward certificate as soon as possible to: Email muhrich@ksstate.bank
or
Fax (785) 587-4016

Please complete the information below and return this form along with the Contract.

City of North Branch, Minnesota

Insurance Company: _____

Agent's Name: _____

Telephone #: _____

Fax #: _____

Address: _____

City, State Zip: _____

Email: _____

PREFERRED

* By completing this form, Obligor is authorizing Obligee to withdraw said payment amount on said date.

DEBIT AUTHORIZATION

I hereby authorize KS StateBank Government Finance Department to initiate debit entries for the Payment Amount (including, but not limited to, any late fees, rate changes, escrow modifications, etc.). I acknowledge that KS StateBank Government Finance Department may reinitiate returned entries up to two additional times, to the account indicated below at the financial institution named below and to debit the same to such account for:

Contract Number 3366939	Payment Amount \$66,510.30	Frequency of Payments Annual
Beginning _____ Month Year	Day of Month Debits will be made according to Exhibit B of the Contract	

I acknowledge that the origination of ACH transactions to this account must comply with the provisions of U.S. law.

Financial Institution Name		Branch	
Address	City	State	Zip
Routing Number		Account Number	

Type of Account Checking Savings

If the account does not have sufficient funds, KS StateBank Government Finance Department may attempt, but shall have no obligation to continue to attempt to deduct the payment from the account. If the account has insufficient funds when KS StateBank Government Finance Department attempts to deduct a payment, KS StateBank Government Finance Department may terminate the automatic deduction of payments upon notice to borrower and me. Until such time as payment is made, borrower shall be responsible to make such payments, and all other payments that may be due to KS StateBank Government Finance Department regarding the above-referenced loan.

This authority is to remain in full force and effect until KS StateBank has received written notification from any authorized signer of the account of its termination in such time and manner as to afford KS StateBank a reasonable opportunity to act on it.

Obligor Name on Contract City of North Branch, Minnesota	
Signature	Printed Name and Title Matthew Hill, City Administrator
Tax ID Number 41-6005421	Date

PLEASE ATTACH COPY OF A VOIDED CHECK TO THIS FORM!

USA Patriot Act

USA Patriot Act requires identity verification for all new accounts. This means that we may require information from you to allow us to make a proper identification.

INVOICE

Date Sent: 01/27/2026

Bill to:
City of North Branch, Minnesota
ATTN: Accounts Payable
6408 Elm Street
North Branch, MN 55056

Account Number: 3366939
Invoice Number: 66939-01-2026
Payment Date: 01-26-2026
Payment Due Date: At Closing
Total Due: \$66,510.30

Description	Amount
Government Obligation Contract Dated as of January 26, 2026 Three (3) 2026 Ford Police Interceptor Vehicles with Upfitting and One (1) 2026 Ford F150 Responder with Upfitting <i>Additional interest will be assessed on any payment received after the due date.</i>	Payment Amount: \$66,510.30
	\$66,510.30
	Total Due

Remit to:
KS StateBank
Government Finance Department
PO Box 1608
Manhattan, KS 66505
For Inquiries: (877) 587-4054
NOTE: The address listed above is for payments only

8038 REVIEW FORM

The 8038 form attached hereto is an important part of the documentation package and must be properly filled out and submitted to the Department of the Treasury in order for you to receive the lower tax-exempt rate. Unless you instruct us otherwise, we have engaged a Paid Preparer to assist in the filling out of this form. The Paid Preparer has filled out the relevant portions of this form based on the current understanding of what is required by the Department of the Treasury. The responses on this 8038 form are based on the dates and amounts which you have requested (structure of the transaction) and which are on the Payment Schedule.

1. Please review our responses for accuracy. If anything is inaccurate, please contact our office so that we can make proper revisions.
2. If the information provided to you on this form is accurate, please sign where indicated and return with the document package.
3. If there are any changes to the structure of the transaction that occur prior to funding which require a change to the 8038 form, we will make such changes and provide notification to you.
4. We will return to you a copy of the 8038 form that was mailed to the Department of the Treasury.

Important Note:

The IRS is now requesting information regarding tax-exempt issuers' and borrowers' written policies and procedures designed to monitor post-issuance compliance with the federal tax rules applicable to tax-exempt obligations (boxes 43 and 44). Do not check items 43 and 44 on the 8038 form unless you have established written procedures in accordance with the instructions referenced directly below. If you choose to "check" items 43 and/or 44, please be prepared to provide copies of such written procedures to the Paid Preparer or any representatives of the IRS upon request. Written procedures should contain certain key characteristics, including making provisions for:

- * Due diligence review at regular intervals;
- * Identifying the official or employee responsible for review;
- * Training of the responsible official/employee;
- * Retention of adequate records to substantiate compliance (e.g., records relating to expenditure of proceeds);
- * Procedures reasonably expected to timely identify noncompliance; and
- * Procedures ensuring that the issuer will take steps to timely correct noncompliance.

For additional guidance on this 8038 form, you can refer to the Documentation Instructions located on the following government website: <http://www.irs.gov/app/picklist/list/formsInstructions.html>, or contact your local IRS office.

▶ Under Internal Revenue Code section 149(e)

▶ See separate instructions.

Department of the Treasury
Internal Revenue Service

Caution: If the issue price is under \$100,000, use Form 8038-GC.

▶ Go to www.irs.gov/F8038G for instructions and the latest information.

Part I Reporting Authority		Check box if Amended Return <input type="checkbox"/>
1 Issuer's name City of North Branch, Minnesota		2 Issuer's employer identification number (EIN) 41-6005421
3a Name of person (other than issuer) with whom the IRS may communicate about this return (see instructions)		3b Telephone number of other person shown on 3a
4 Number and street (or P.O. box if mail is not delivered to street address) 6408 Elm Street	Room/suite	5 Report number (For IRS Use Only) 3
6 City, town, or post office, state, and ZIP code North Branch, MN 55056		7 Date of issue 1/26/2026
8 Name of issue Government Obligation Contract		9 CUSIP number None
10a Name and title of officer or other employee of the issuer whom the IRS may call for more information Matthew Hill, City Administrator		10b Telephone number of officer or other employee shown on 10a 651-277-5229

Part II Type of Issue (Enter the issue price.) See the instructions and attach schedule.	
11 Education	11
12 Health and hospital	12
13 Transportation	13
14 Public safety	14
15 Environment (including sewage bonds)	15
16 Housing	16
17 Utilities	17
18 Other. Describe ▶ Three (3) 2026 Ford Police Interceptor Vehicles with Upfitting and One (1) 2026 Ford	18 299,908.01
19a If bonds are TANs or RANs, check only box 19a ▶ <input type="checkbox"/>	
b If bonds are BANs, check only box 19b ▶ <input type="checkbox"/>	
20 If bonds are in the form of a lease or installment sale, check box ▶ <input type="checkbox"/>	

Part III Description of Bonds. Complete for the entire issue for which this form is being filed.					
	(a) Final maturity date	(b) Issue price	(c) Stated redemption price at maturity	(d) Weighted average maturity	(e) Yield
21	1/26/2030	\$ 299,908.01	\$ 299,908.01	4 years	5.378 %

Part IV Uses of Proceeds of Bond Issue (including underwriters' discount)	
22 Proceeds used for accrued interest	22
23 Issue price of entire issue (enter amount from line 21, column (b))	23 299,908.01
24 Proceeds used for bond issuance costs (including underwriters' discount)	24 0.00
25 Proceeds used for credit enhancement	25
26 Proceeds allocated to reasonably required reserve or replacement fund	26
27 Proceeds used to refund prior tax-exempt bonds. Complete Part V	27
28 Proceeds used to refund prior taxable bonds. Complete Part V	28
29 Total (add lines 24 through 28)	29 0.00
30 Nonrefunding proceeds of the issue (subtract line 29 from line 23 and enter amount here)	30 299,908.01

Part V Description of Refunded Bonds. Complete this part only for refunding bonds.	
31 Enter the remaining weighted average maturity of the tax-exempt bonds to be refunded ▶	_____ years
32 Enter the remaining weighted average maturity of the taxable bonds to be refunded ▶	_____ years
33 Enter the last date on which the refunded tax-exempt bonds will be called (MM/DD/YYYY) ▶	_____
34 Enter the date(s) the refunded bonds were issued ▶ (MM/DD/YYYY)	_____

Part VI Miscellaneous

35	Enter the amount of the state volume cap allocated to the issue under section 141(b)(5)	35	
36a	Enter the amount of gross proceeds invested or to be invested in a guaranteed investment contract (GIC). See instructions	36a	
b	Enter the final maturity date of the GIC ▶ (MM/DD/YYYY) _____		
c	Enter the name of the GIC provider ▶ _____		
37	Pooled financings: Enter the amount of the proceeds of this issue that are to be used to make loans to other governmental units	37	
38a	If this issue is a loan made from the proceeds of another tax-exempt issue, check box <input type="checkbox"/> and enter the following information:		
b	Enter the date of the master pool bond ▶ (MM/DD/YYYY) _____		
c	Enter the EIN of the issuer of the master pool bond ▶ _____		
d	Enter the name of the issuer of the master pool bond ▶ _____		
39	If the issuer has designated the issue under section 265(b)(3)(B)(i)(III) (small issuer exception), check box		<input checked="" type="checkbox"/>
40	If the issuer has elected to pay a penalty in lieu of arbitrage rebate, check box		<input type="checkbox"/>
41a	If the issuer has identified a hedge, check here <input type="checkbox"/> and enter the following information:		
b	Name of hedge provider ▶ _____		
c	Type of hedge ▶ _____		
d	Term of hedge ▶ _____		
42	If the issuer has superintegrated the hedge, check box		<input type="checkbox"/>
43	If the issuer has established written procedures to ensure that all nonqualified bonds of this issue are remediated according to the requirements under the Code and Regulations (see instructions), check box		<input type="checkbox"/>
44	If the issuer has established written procedures to monitor the requirements of section 148, check box		<input type="checkbox"/>
45a	If some portion of the proceeds was used to reimburse expenditures, check here <input type="checkbox"/> and enter the amount of reimbursement ▶ _____		
b	Enter the date the official intent was adopted ▶ (MM/DD/YYYY) _____		

Signature and Consent	Under penalties of perjury, I declare that I have examined this return and accompanying schedules and statements, and to the best of my knowledge and belief, they are true, correct, and complete. I further declare that I consent to the IRS's disclosure of the issuer's return information, as necessary to process this return, to the person that I have authorized above.		
	Signature of issuer's authorized representative	Date	Type or print name and title
Paid Preparer Use Only	Print/Type preparer's name H. Evan Howe	Preparer's signature 	Date 1/27/2026
	Firm's name ▶ Baystone Financial LLC	Firm's EIN ▶ 48-1223987	Check <input type="checkbox"/> if self-employed PTIN P01438994
	Firm's address ▶ 10601 Mission Road, Suite 200, Leawood, KS 66206	Phone no. (800) 752-3562	



Prepared By: Sharon Wright, Finance Director

Presenter: Sharon Wright, Finance Director

Date: 01/30/2026

Board & Commission: City Council

Subject: Approval of Resolution R-286-2026 Accepting 2025 Donations to the City of North Branch

Minnesota Cities have the authority to accept gifts and donations. However, Minnesota law requires cities to accept all donations by passing a formal resolution.

The City of North Branch has received the following donations during the 2025 fiscal year.

When	By Whom	Purpose	Amount
03/10/2025	Newman Mgmt	PD Donation	30.00
07/10/2025	Members Coop CU	PD Donation	250.00
10/02/2025	David Mellgran	PD Donation	75.00
10/28/2025	Newman Mgmt	PD Donation	250.00
11/13/2025	Tom Kadlec Chevy	First Responders	500.00
11/20/2025	PDI Foods/McDonald's	McHero Night	878.00
06/23/2025	North Branch Fire Relief Association	Fireworks	14,965.06
09/24/2025	North Branch Liquor Store	Firefighter Donations	4,034.74
11/26/2025	North Branch Fire Relief Association	Fire Equipment Donation	20,000.00
12/23/2025	North Branch Fire Relief Association	Fire Equipment Donation	15,000.00
12/30/2025	North Branch Fire Relief Association	Fire Equipment Donation	22,000.00

Voting Requirements:

Voting Options Simple Majority

STATE OF MINNESOTA

COUNTY OF CHISAGO

CITY OF NORTH BRANCH

CITY COUNCIL RESOLUTION NO. R-286-2026

Resolution to Accept 2025 Donations to the City of North Branch

WHEREAS, Minnesota Statutes Section 465.03 (gifts to municipalities) provides that donations to the City be accepted by resolution of the City Council; and

WHEREAS, The City of North Branch received donations in the year 2025 from various individuals and organizations.

NOW, Therefore, Be it Resolved by the City Council of North Branch, Minnesota that the donations are accepted in accordance with the terms prescribed by the donors.

Passed by the City Council of North Branch, Minnesota this 11th day of February 2026.

Kevin Schieber, Mayor

Attest:

Tonya Kostuch, City Clerk



NORTH BRANCH
City of North Branch
Staff Report

Prepared By: Nathan Sondrol, Community Development Director

Presenter: Nathan Sondrol, Community Development Director

Date: 02/03/2026

Board & Commission: City Council

Subject: Approval of Resolution R-289-2026 to apply for a DNR Local Trail Connections grant for Flink Ave Phase II Trail

REQUESTED ACTION

To recommend approval of Resolution R-289-206 to authorize city staff to submit a grant application for the Flink Ave Trail Phase II project to the DNR Local Trail connections grant program.

Introduction

The Minnesota DNR is soliciting applications for the Local Trail Connections Program with an application deadline of March 31, 2026.

This program provides grants to local units of government to promote relatively short trail connections between where people live and desirable locations, not to develop significant new trails. Funding for this grant program is from "In Lieu Of" lottery proceeds.

Eligible projects

Eligible projects include acquisition and development of trail facilities. Projects must result in a trail linkage that is immediately available for use by the general public. Trail linkages include connecting where people live (e.g. residential areas within cities, entire communities) and significant public resources (e.g. historical areas, open space, parks and/or other trails). Acquisition of trail right-of-way is eligible only when proposed in conjunction with trail development. Acquisition projects require a perpetual easement for recreational purposes. Development projects require a 20 year maintenance commitment by the project sponsor. Projects inside state park boundaries, state recreation areas, on state trail corridors and elements of the Regional Open Space System in the Twin Cities Metro System are not eligible.

Funding priorities

Priority for trail project funding will be given to projects that provide significant connectivity, will meet the needs and interests of future generations and diverse communities, provide an

opportunity to connect underserved communities to significant public resources and provide for a unique and interesting connection to the outdoors. Considerations also include trail length, expected amount and type of use, and quality and attractiveness of natural and cultural resources.

Background/Overview

The City Council approved Resolution R-5-2024 in February 2024 authorizing City staff to submit an application to the MnDOT Active Transportation (AT) Grant Program for the Flink Ave Trail Phase II Improvement Project. The Flink Ave Phase II Improvement project consists of the construction of a 10’ wide trail located on the west side of Flink Ave from 392nd Street to the existing pedestrian network located on the north side of the entrance to the North Branch Marketplace development.

The City was notified in May 2024 that the proposed project was selected for MnDOT Active Transportation Program Funds in the amount of \$574,332 for infrastructure improvements for the project.

The City Council approved a resolution authorizing WSB to provide engineering and construction inspection services for the project on January 28, 2025, and approved Resolution R-195-2025 on May 27, 2025, to approve the plans and specs and authorizing city staff to advertise for bids. The City received 6 bids for the project, all exceeding the budgeted grant award amount, with the low bid of \$1,557,221. City staff have been working with MnDot on the ability to extend the construction of the trail to start by June 2027 to allow for seeking future grant funding solicitations to assist with completing the project.

The DNR has a current local trail connection grant program solicitation that provides up to \$250,000 with a non-state cash match of at least 25 percent. This would require a minimum of \$62,500 commitment. Potential funding sources include the Park Dedication Fund, Park Improvement Fund and Municipal State Aid Street Funds. The grant applications are due March 31, 2026, and will be announced in summer 2026.

The Parks, Trails and Open Space Commission recommended approval of submitting an application to the DNR Local Trail Connections grant program for the Flink Ave Trail Phase II project.

REQUESTED ACTION

To recommend approval of Resolution R-289-206 to authorize city staff to submit a grant application for the Flink Ave Trail Phase II project to the DNR Local Trail connections grant program.

Voting Requirements:

Voting Options Simple Majority

STATE OF MINNESOTA

COUNTY OF CHISAGO

CITY OF NORTH BRANCH

CITY COUNCIL RESOLUTION NO. R-289-2026

RESOLUTION TO APPLY FOR A DNR LOCAL TRAIL CONNECTIONS GRANT FOR THE FLINK AVE PHASE II TRAIL

WHEREAS, the City of North Branch supports the grant application made to the Minnesota Department of Natural Resources for the Local Trail Connections Program. The application is to construct approximately 0.3 miles of paved trail for the Flink Avenue Phase II Trail System.

WHEREAS, The trail system provides connections from the Meadows North residential development to the Sunrise River, Regional Shopping Center and the entire city’s trail system, including the Sunrise Prairie Regional Trail (US Bike Route 41), and

WHEREAS, the City of North Branch recognizes that it has secured \$565,700 in state cash matching funds through the Minnesota Department of Transportation Active Transportation grant program for this project.

WHEREAS, the City of North Branch recognizes that it has secured a minimum of \$62,500 in non-state cash matching funds for this project.

NOW, THEREFORE, BE IT RESOLVED, if the City of North Branch is awarded a grant by the Minnesota Department of Natural resources, the City of North Branch agrees to accept the grant award, and may enter into an agreement with the State of Minnesota for the above referenced project. The City of North Branch will comply with all applicable laws, environmental requirements and regulations as stated in the grant agreement, and

BE IT FURTHER RESOLVED that the applicant has read the Conflict of Interest Policy contained in the Local Trail Connections Grant Manual and certifies it will report any actual, potential, perceived, or organizational conflicts of interest upon discovery to the state related to the application or grant award.

BE IT FURTHER RESOLVED, the City Council of the City of North Branch names the fiscal agent for the City of North Branch for this project as:

Sharon Wright
Finance Director
City of North Branch
PO Box 910 - 6408 Elm St

North Branch, MN 55056

BE IT FURTHER RESOLVED, the City of North Branch hereby assures the Flink Ave Phase II Recreational Trail will be maintained for a period of no less than 20 years.

PASSED AND ADOPTED BY THE CITY COUNCIL OF THE CITY OF NORTH BRANHC
THIS 11TH DAY OF February, 2026.

Kevin Scheiber, Mayor

ATTEST:

Tonya Kostuch, City Clerk

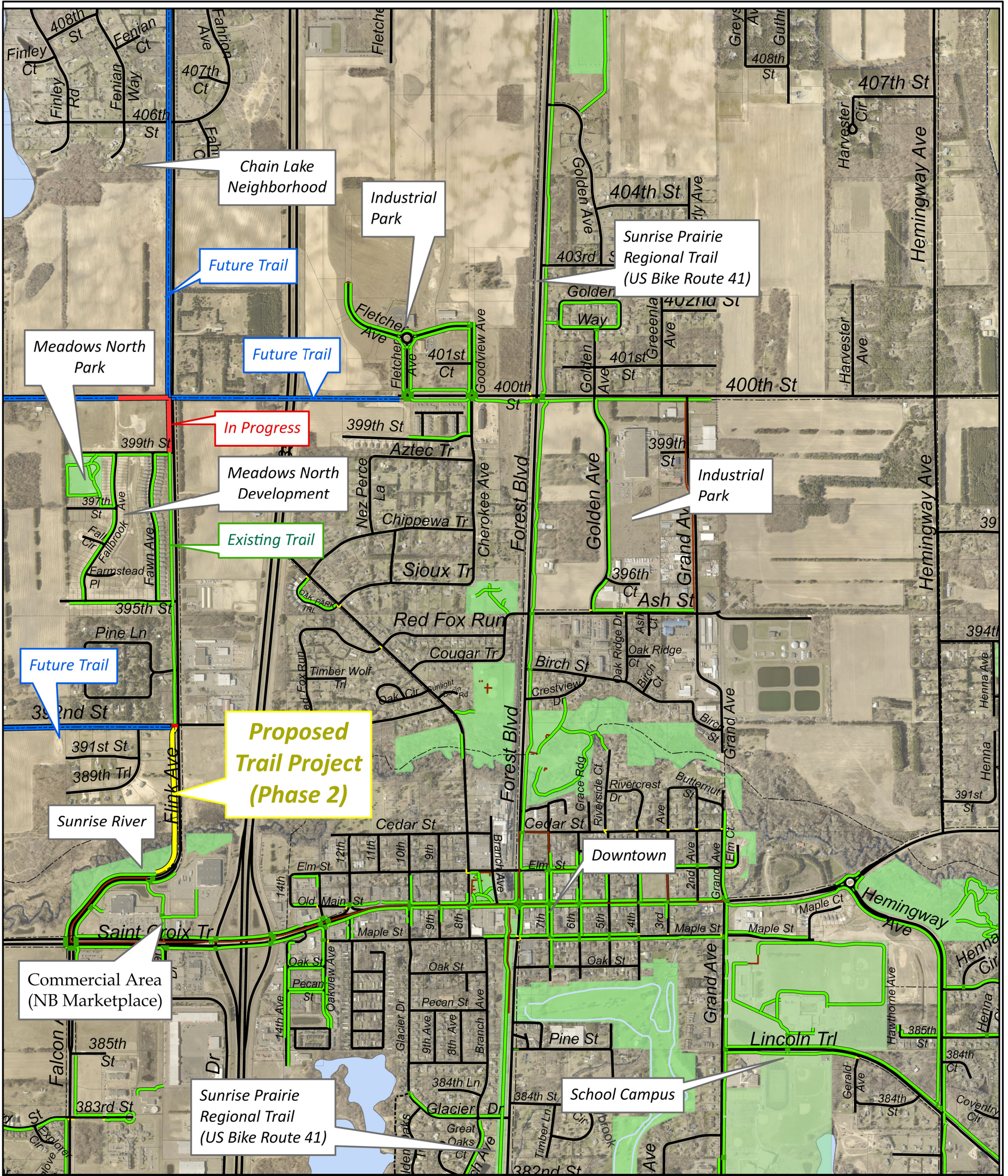

- Proposed Trail
- In Progress
- Existing Facilities
- Future Trail

Flink Ave Trail Project Phase II
392nd St - NB Marketplace
North Branch - Chisago County, MN

Project Location Map



Date: Nov 30, 2023

Scale: 1":1,500'



Prepared By: Nathan Sondrol, Community Development Director

Presenter: Nathan Sondrol, Community Development Director

Date: 02/03/2026

Board & Commission: City Council

Subject: Approval of Resolution R-290-2026 to submit a capital funding request for the Circle of Honor Regional Veterans Memorial

Requested Action

Approval of resolution R-290-2026 to provide support for the North Branch Veterans Memorial Committees Circle of Honor Veterans Regional Veterans Memorial capital grant application to the state capital grant fund

Background Info

The North Branch City Council approved the North Branch Veteran's Memorial Committee request to construct a veterans memorial in Central Park and entered into an MOU agreement for the construction of the Veterans Memorial.

The North Branch Veterans Memorial Committee has been conducting fundraising efforts for the memorial and is looking to apply for a state of Minnesota capital grant for the project. The capital grant requires a resolution providing support from the local agency (city) for the project and to prioritize the ranking of the project.

The City Council approved authorizing the city to enter into an agreement with North Branch Veterans Memorial Committee for the city to act as a fiscal agent for grants at the October 8, 2024, meeting.

Attached is the approved fiscal agreement and approved site plan for the memorial.

Voting Requirements:

Voting Options Simple Majority

STATE OF MINNESOTA

COUNTY OF CHISAGO

CITY OF NORTH BRANCH

CITY COUNCIL RESOLUTION NO. R-290-2026

A RESOLUTION OF SUPPORT FOR THE NORTH BRANCH VETERANS MEMORIAL COMMITTEE CAPITAL PROJECT APPLICATION TO MINNESOTA MANAGEMENT BUDGET (MMB) FOR THE CIRCLE OF HONOR REGIONAL VETERANS MEMORIAL PROJECT

WHEREAS, the City of North Branch has entered into an Memorandum of Understanding with the North Branch Veterans Memorial Committee, under the direction and financial management of the North Branch Beautification Association; and

WHEREAS, the City of North Branch has approved a site plan for the Circle of Honor Regional Veterans Memorial project in Central Park, located at 6250 Main Street; and

WHEREAS, the North Branch Veterans Memorial Committee will seek state funding for capital improvements for the Circle of Honor Regional Veterans Memorial Committee; and

NOW THEREFORE BE IT RESOLVED by the City Council of the City of North Branch: That the City supports the following projects for the 2025 legislative session and that the following capital investment projects are prioritized to the Minnesota Management and Budget Office in the order below:

- 1. City of North Branch 400th Street/Interstate 35 Interchange
- 2. Circle of Honor Regional Veterans Memorial

PASSED AND ADOPTED BY THE CITY COUNCIL OF THE CITY OF NORTH BRANCH
THIS 11TH DAY OF February, 2026.

Kevin Scheiber, Mayor

Date

Tonya Kostuch, City Clerk

**Fiscal Agent Agreement between
the City of North Branch
and North Branch Veterans Memorial Committee**

This agreement is made this 8th day of October, 2024, between the City of North Branch, Minnesota (“Fiscal Agent”) and North Branch Beautification Association Veterans Memorial Committee (“Operating Entity”).

Purpose of Agreement

The Operating Entity has proposed that the Fiscal Agent sponsor a project (the “Project”) to do the following (describe):

Financial Grant Administration for a Veterans Memorial within the City of North Branch’s city limits.

The Fiscal Agent has determined that sponsorship of the Project would be consistent with its goals and wishes to work with the Operating Entity for the implementation and operation of the Project.

1. The fiscal Agent hereby agrees to sponsor the Project and to assume financial grant administration for the purposes of the requirements of the funding organization in accordance with the City’s Fiscal Agent Services Policy included within the City’s Financial Management Policy. The Operating Entity agrees to implement and operate the Project, in accordance with the terms of this agreement and with the terms and conditions of any grants received or restricted funds donated to said project. This agreement is for sole purposes of said project for the solicitation and administration of grant funding and the fiscal agent has no control over any other of the operating entity’s financial accounts.
2. The Project shall be operated in a manner consistent with the Fiscal Agent’s legal requirements and as described in this agreement. No material changes in the purposes or activities of the Project shall be made without prior written permission of the Fiscal Agent and in accordance with any requirements of the grant award, nor shall the Operating Entity carry on activities or use funds in any way that jeopardizes the Fiscal Agent’s status.
3. The Operating Entity will provide all information and prepare all reports, including interim and final reports that may be required by any grant contracts. The Fiscal Agent will provide monthly financial reports to the Operating Entity showing revenue and expenditure details to include as documentation with the grant reports.
4. The Operating Entity will not assign nor transfer any of its duties as described in the Project’s work plan without the consent of the Fiscal Agent and the subsequent review and approval of any subcontractor agreements.
5. On behalf of the Operating Entity, the Fiscal Agent will establish and operate for the use of the Project, a designated account (“account”) segregated on the fiscal Agents books. All amounts deposited into a Project’s Account will be used in its support, less administrative charges, if any, and subject to the conditions set forth below.

6. The fiscal Agent will disburse funds from the Account in the following manner:

Operating Entity will provide detailed invoices from each vendor. Invoices presented for payment must be given to the Fiscal Agent within fifteen (15) days of their due date so late charges do not accrue. The detailed invoice shall include the name of the person or company providing the materials or services, address, telephone number, the date(s) the work/service/materials was done, scope of work completed (first payment, final payment, etc), and invoice due date.

These detailed invoices must be accompanied by an attested statement which says the following: "I affirm this claim is just and correct and that no part of it has been previously paid and that the items billed for have been received by the Operating Entity."

Disbursements will be restricted to the support and implementation of the Project only.

7. The Operating Entity designates _____ (name(s) or title(s)) to act as authorizing official(s). The authorizing official shall act as principal coordinator of the Project's daily business with the Fiscal Agent and shall have the sole authority to sign disbursement requests.
8. The Fiscal Agent designates _____ (name or title) as the authorized official to serve as the primary contact with both the Grantor organization and the Authorizing Official of the Operating Entity.
9. The Fiscal Agent and Operating Entity will maintain all financial records relating to the Project according to generally accepted accounting principles.
10. The Operating Entity will reflect the activities of the Project to the extent required, on their state and federal government tax returns and financial reports. All disbursements from an Account shall be treated as payments made to or on behalf of the Operating Entity to accomplish the purposes of this Project. The sponsored organization will provide the Fiscal Agent with proper documentation to accomplish this, including furnishing the Fiscal Agent with the Operating Entity's Federal Employer Identification Number.
11. This agreement, including any amendments, will terminate if any of the following events occur:
 - a. The Fiscal Agent requests the Operating Entity to cease activities that it deems might jeopardize its legal status and the Project fails to comply within a period of ten days;
 - b. The Operating Entity fails to raise sufficient funds to accomplish the construction of the Veterans Memorial within three years of the execution date of this agreement.
 - c. The Operating Entity fails to perform or observe any other covenant of this agreement, and this failure remains unremedied fifteen (15) days after notice in writing;
 - d. Upon expiration of four weeks after either the fiscal Agent or Operating Entity has given written notice of its intent to terminate the agreement.
 - e. This agreement shall only be for the financial grant administration for the Veterans Memorial project and shall terminate upon completion.

- 12. In the event this Agreement is terminated, the Fiscal Agent will process any final invoices approved for payment and then prepare a final report of funds for the Operating Entity. Any remaining funds will be returned to the Operating Entity within fifteen days of the termination. The Operating Entity will be responsible for any reporting to grantors and/or donors with respect to the termination of the agreement and the status of the remaining funds.
- 13. Operating Entity hereby agrees to defend, indemnify, and hold harmless the Fiscal Agent from any liability, claims, or causes of action arising from said project.
- 14. Nothing in this agreement shall be construed or implied to create a partnership, joint venture, or joint powers entity.
- 15. This Agreement shall supersede any prior oral or written understandings or communications between the parties hereto and constitutes the entire agreement of the parties hereto with respect to the subject matter hereof, excluding the existing Veterans Memorial MOU. This Agreement may not be amended or modified, except in writing and as signed by both parties hereto. Should any part of this Agreement be deemed invalid or unenforceable as for any reason whatsoever, the remaining portions hereof shall remain in full force and effect as though those portions deemed invalid or unenforceable had never been included therein.
- 16. This Agreement may be executed in one or more counterparts, each of which when so executed shall be deemed to be an original and all of which taken together shall constitute one and the same agreement.

In witness whereof, the parties hereto have executed this Agreement on the day and year first written above.

Accepted for the Fiscal Agent:

Accepted for the Operating Entity

 Printed Name of Authorized Signer

 Printed Name of Authorized Signer

 Signature of Authorized Signer

 Signature of Authorized Signer

 Date

 Date

CENTRAL PARK - VETERAN'S MEMORIAL

North Branch, Minnesota

WSB Project No. 023090-000
 Issue Date..... 10/04/2023

SHEET LIST TABLE	
SHEET NUMBER	SHEET TITLE
L1.0	TITLE SHEET
L2.0	LAYOUT PLAN
L3.0	GRADING PLAN
L4.0	PLANTING PLAN
L5.0	DETAILS

SCALE: AS SHOWN
 PLAN BY: KP
 DESIGN BY: KP
 CHECK BY: RS

REVISIONS	
NO.	DESCRIPTION

I HEREBY CERTIFY THAT THIS PLAN, SPECIFICATION, OR REPORT WAS PREPARED BY ME OR UNDER MY DIRECT SUPERVISION AND THAT I AM A DULY LICENSED LANDSCAPE ARCHITECT UNDER THE LAWS OF THE STATE OF MINNESOTA.

Robert A. Slijka III
 DATE: 10/04/2023 LIC. NO.: 44337



TITLE SHEET

Veteran's Memorial
 City of North Branch

1 PROJECT LOCATION MAP
 L1.0 SCALE: NOT TO SCALE

CLIENT PROJECT NO. XXXXXX
 WSB PROJECT NO. 023090-000
 SHEET

K:\023090-000\Cad\Plan\023090-000-L1-TITLE-PLAN.dwg 10/4/2023 9:16:30 AM

REVISIONS	
NO.	DESCRIPTION

I HEREBY CERTIFY THAT THIS PLAN, SPECIFICATION, OR REPORT WAS PREPARED BY ME OR UNDER MY DIRECT SUPERVISION AND THAT I AM A DULY LICENSED LANDSCAPE ARCHITECT UNDER THE LAWS OF THE STATE OF MINNESOTA.

Robert A. Slijka III
 DATE: 10/04/2023 LIC. NO.: 44337

GRADING PLAN

Veteran's Memorial
 City of North Branch

CLIENT PROJECT NO.
 XXXXXX

WSB PROJECT NO.
 023090-000

SHEET

K:\023090-000\Cad\Plan\023090-000-LP-GRAD-PLAN.dwg 10/4/2023 9:16:44 AM

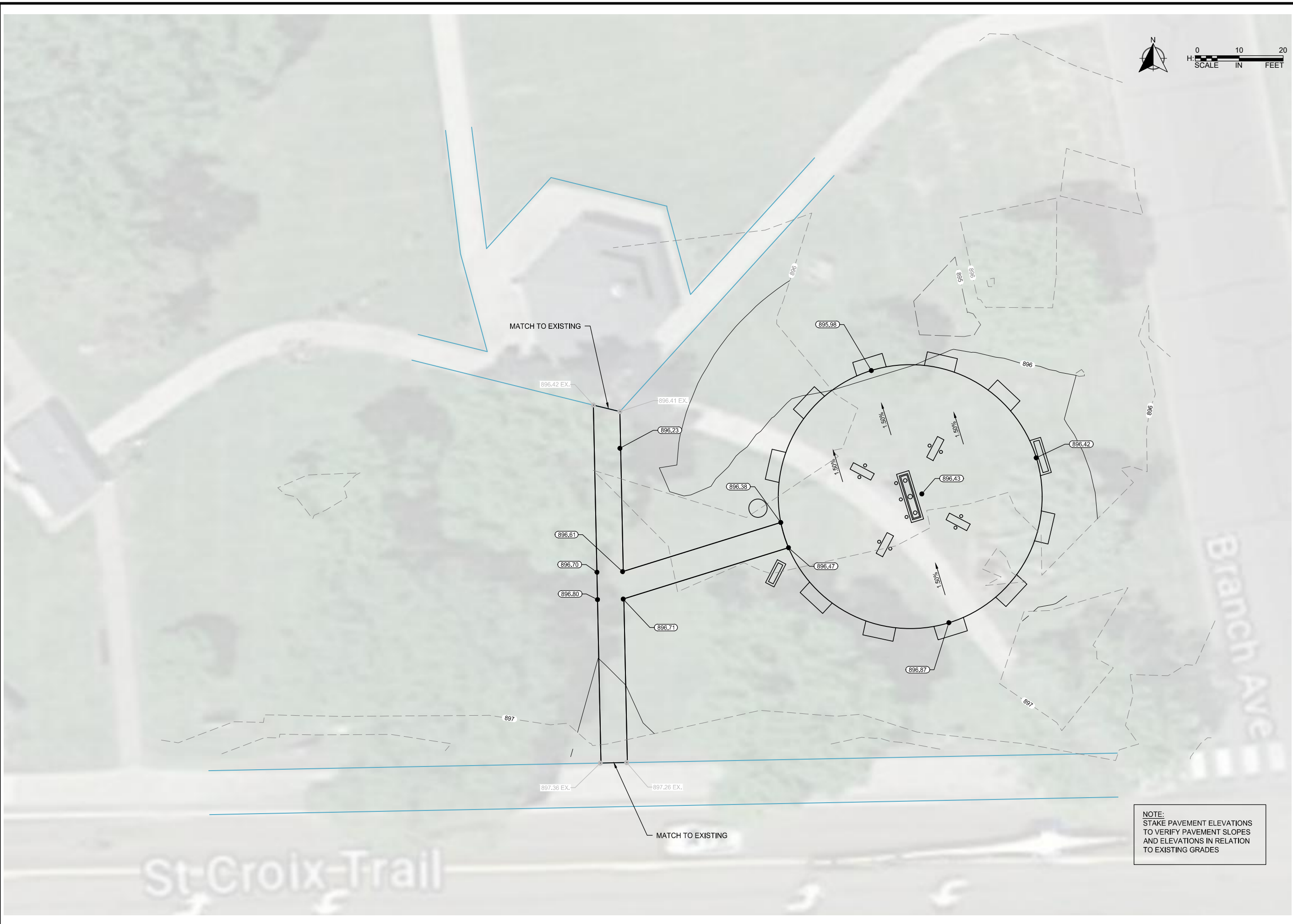

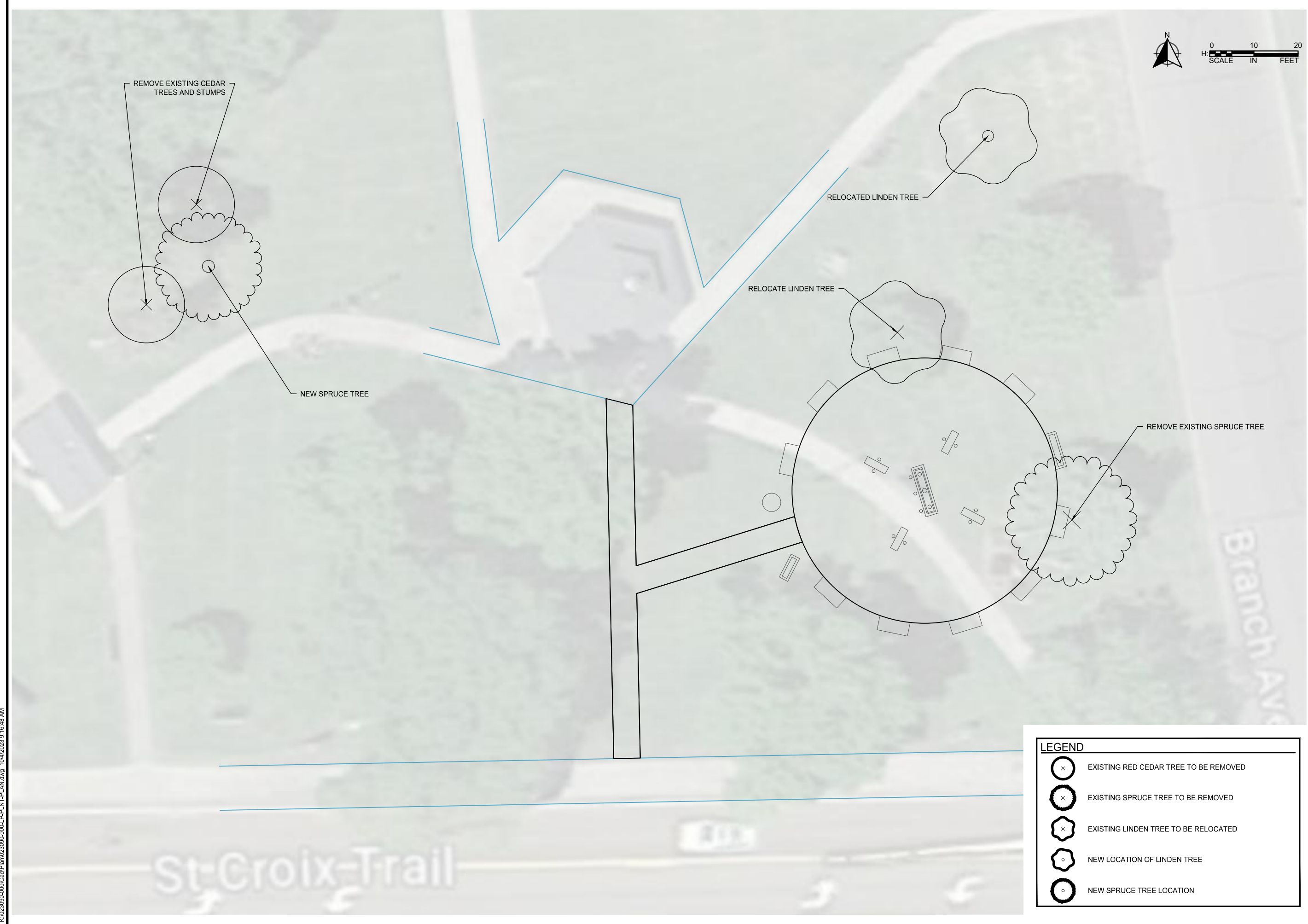

REVISIONS

NO.	DATE	DESCRIPTION

I HEREBY CERTIFY THAT THIS PLAN, SPECIFICATION, OR REPORT WAS PREPARED BY ME OR UNDER MY DIRECT SUPERVISION AND THAT I AM A DULY LICENSED LANDSCAPE ARCHITECT UNDER THE LAWS OF THE STATE OF MINNESOTA.

Robert A. Slijka III
 DATE: 10/04/2023 LIC. NO.: 44337

PLANTING PLAN

Veteran's Memorial
 City of North Branch

LEGEND

	EXISTING RED CEDAR TREE TO BE REMOVED
	EXISTING SPRUCE TREE TO BE REMOVED
	EXISTING LINDEN TREE TO BE RELOCATED
	NEW LOCATION OF LINDEN TREE
	NEW SPRUCE TREE LOCATION

CLIENT PROJECT NO.
 XXXXXX

WSB PROJECT NO.
 023090-000

SHEET
 L4.0
 Page 128 of 148

REVISIONS	
NO.	DESCRIPTION

I HEREBY CERTIFY THAT THIS PLAN, SPECIFICATION, OR REPORT WAS PREPARED BY ME OR UNDER MY DIRECT SUPERVISION AND THAT I AM A DULY LICENSED LANDSCAPE ARCHITECT UNDER THE LAWS OF THE STATE OF MINNESOTA.

Robert A. Slijka III
 DATE: 10/04/2023 LIC. NO.: 44337

DETAILS

Veteran's Memorial
 City of North Branch

CLIENT PROJECT NO. XXXXXX

WSB PROJECT NO. 023090-000

SHEET

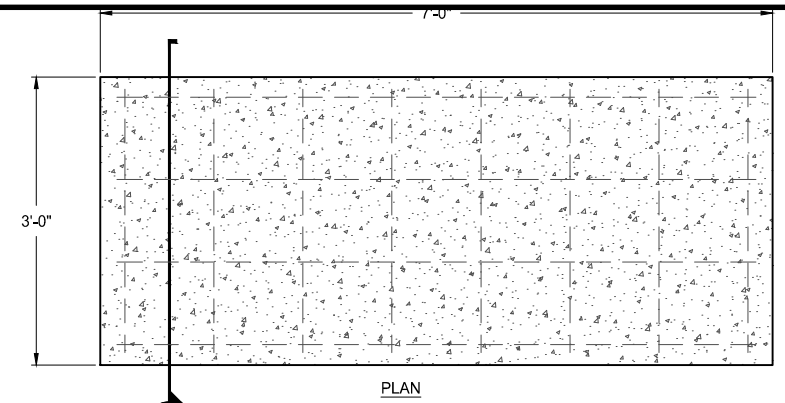

PLAN

1
L5.0

NOTE:
 VERIFY COLOR AND FINISH WITH OWNER

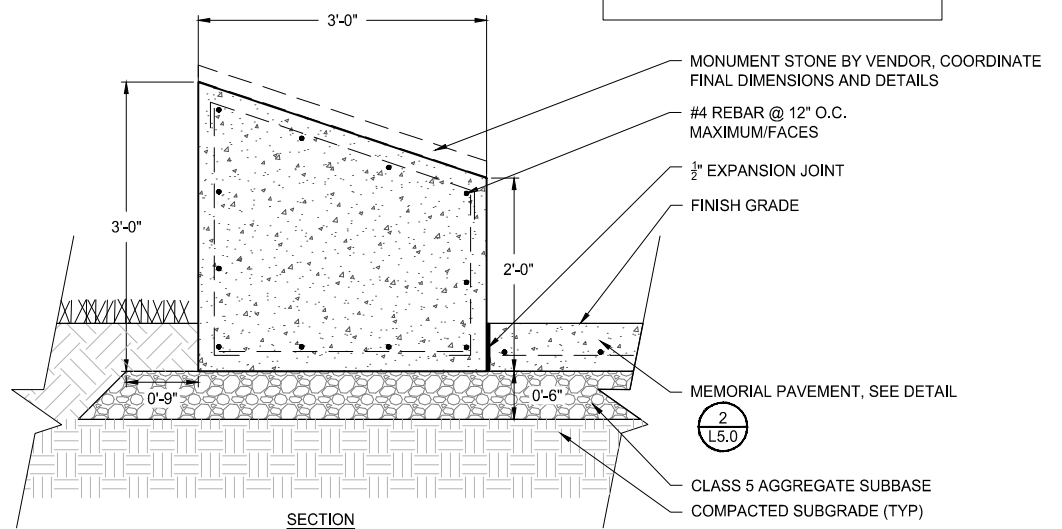

SECTION

2
L5.0

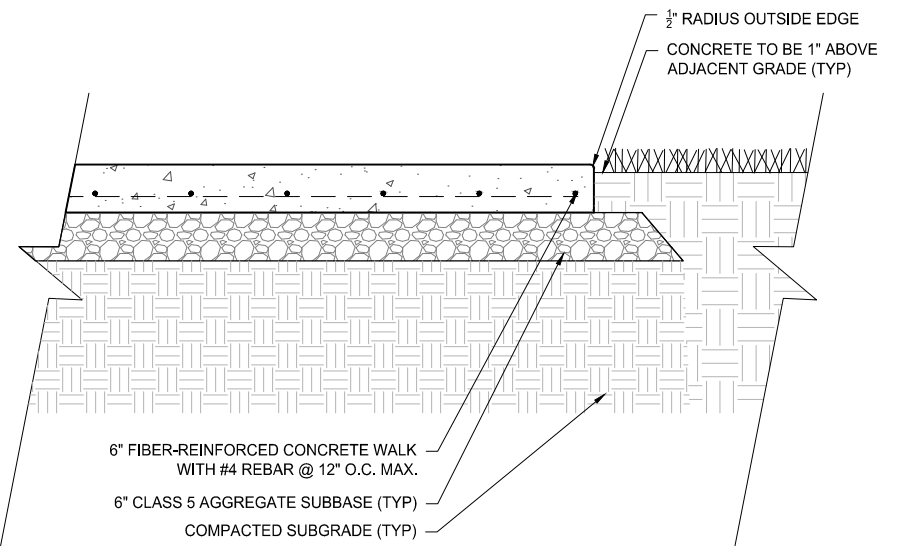

6" FIBER-REINFORCED CONCRETE WALK WITH #4 REBAR @ 12" O.C. MAX.
 6" CLASS 5 AGGREGATE SUBBASE (TYP)
 COMPACTED SUBGRADE (TYP)

NOTE:
 VERIFY COLOR AND FINISH WITH OWNER

2
L5.0

MEMORIAL PAVEMENT

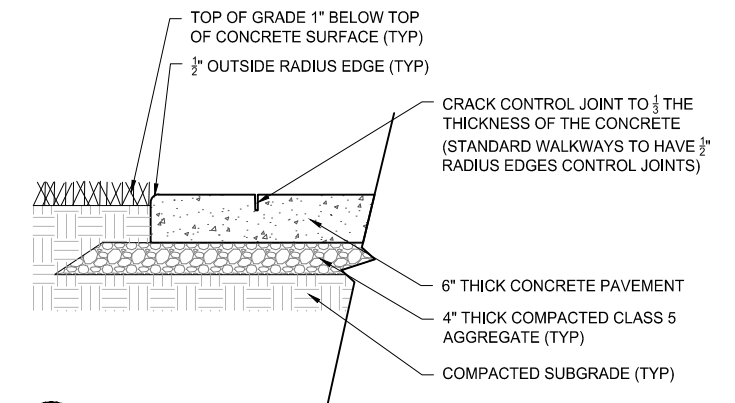

CRACK CONTROL JOINT TO 1/3 THE THICKNESS OF THE CONCRETE (STANDARD WALKWAYS TO HAVE 1/2" RADIUS EDGES CONTROL JOINTS)

3
L5.0

TYPICAL 6' CONCRETE SIDEWALK

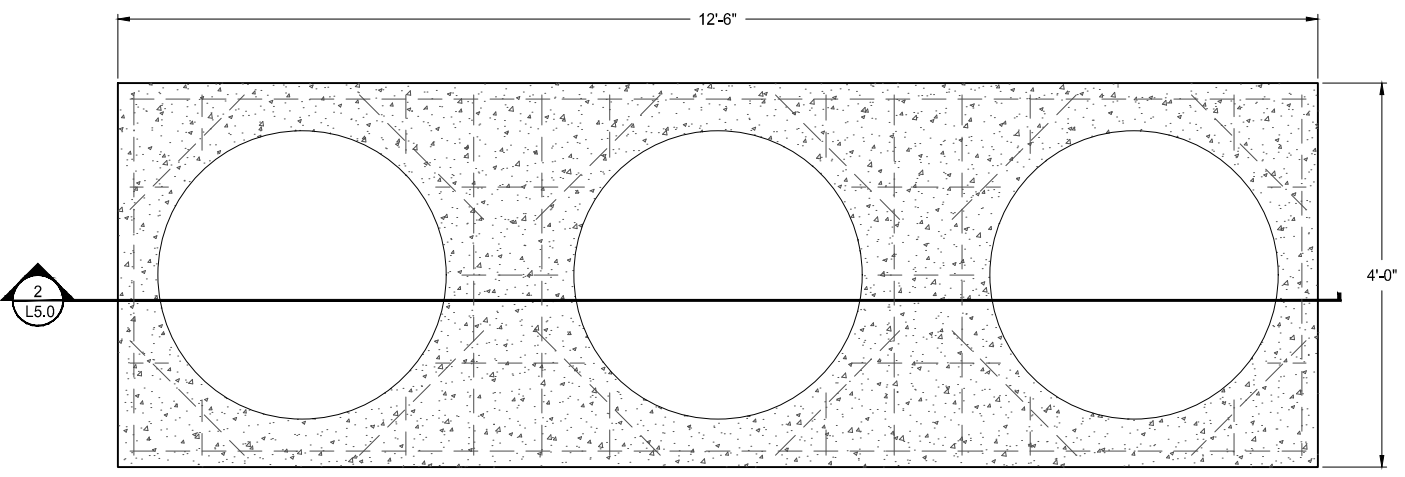

2
L5.0

NOTE:
 VERIFY COLOR AND FINISH WITH OWNER

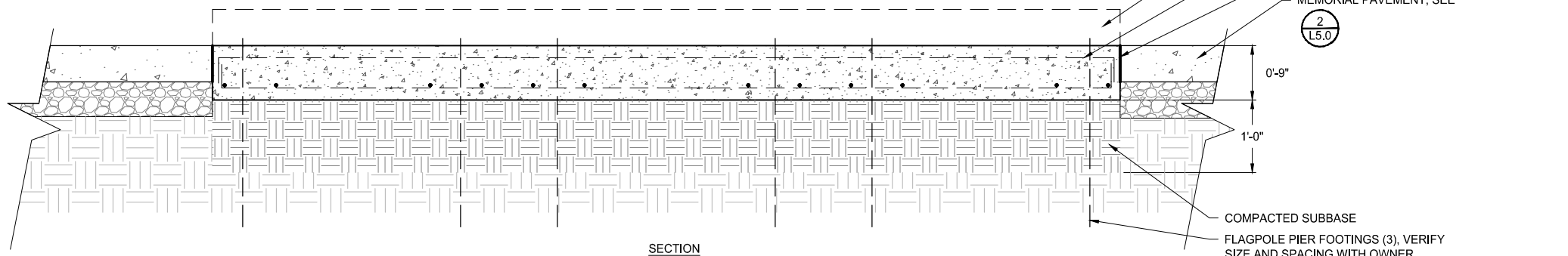

SECTION

2
L5.0

4
L5.0

BASE SUPPORT FOR FLAGPOLES

MONUMENT STONE BY VENDOR, COORDINATE FINAL DIMENSIONS AND DETAILS
 #4 REBAR @ 11" MAX. O.C. (TOP & BOTTOM)
 EXPANSION JOINT
 MEMORIAL PAVEMENT, SEE

COMPACTED SUBBASE
 FLAGPOLE PIER FOOTINGS (3), VERIFY SIZE AND SPACING WITH OWNER

K:\023090-000\Cad\Plan\023090-000-LP-DTL5.dwg 10/4/2023 9:16:53 AM



Prepared By: Sharon Wright, Finance Director

Presenter: Sharon Wright, Finance Director

Date: 02/04/2026

Board & Commission: City Council

Subject: Approval of Resolution R-288-2026 to authorize the Sale of Equipment Bonds

The City is considering the issuance of Equipment Bonds in the amount of \$3,075,000. The proposed bond would fund the purchase of several capital items, including a ladder truck and a tanker truck for the Fire Department, and for the Public Works Department three (3) snow plows, a one-ton four-wheel-drive plow truck, and a front-end loader.

These purchases would replace obsolete equipment which would be sold at auction. Proceeds from the auction would be deposited into a designated fund to support future equipment replacement and capital needs.

City Council is asked to approve Resolution R-288-2026 authorizing the City and Ehlers to proceed with the bond sale.

Voting Requirements:

Voting Options Simple Majority

STATE OF MINNESOTA

COUNTY OF CHISAGO

CITY OF NORTH BRANCH

CITY COUNCIL RESOLUTION NO. R-288-2026

Resolution R-288-2026 Approving the Sale of \$3,075,000 General Obligation Bonds, Series 2026A

WHEREAS, the City Council of the City of North Branch, Minnesota has heretofore determined that it is necessary and expedient to issue the City's \$3,075,000 General Obligation Bonds, Series 2026A (the "Bonds"), to finance the purchase of various equipment for the City; and

WHEREAS, the City has retained Ehlers & Associates, Inc., in Minneapolis, Minnesota ("Ehlers"), as its independent municipal advisor for the Bonds in accordance with Minnesota Statutes, Section 475.60, subdivision 2(9);

NOW, Therefore, be it Resolved by the City Council of the City of North Branch, Minnesota, as follows:

City of North Branch, Minnesota

\$3,280,000 General Obligation Equipment Certificates, Series 2026A
Assumes Current Market BQ AA Rates plus 50bps

Sources & Uses

Dated 04/01/2026 | Delivered 04/01/2026

Sources Of Funds

Par Amount of Bonds	\$3,280,000.00
Total Sources	\$3,280,000.00

Uses Of Funds

Total Underwriter's Discount (1.200%)	39,360.00
Costs of Issuance	68,000.00
Deposit to Capitalized Interest (CIF) Fund	95,702.08
Deposit to Project Construction Fund	3,075,000.00
Rounding Amount	1,937.92
Total Uses	\$3,280,000.00

City of North Branch, Minnesota

\$3,280,000 General Obligation Equipment Certificates, Series 2026A

Assumes Current Market BQ AA Rates plus 50bps

Net Debt Service Schedule

Date	Principal	Coupon	Interest	Total P+I	CIF	Net New D/S	Fiscal Total
04/01/2026	-	-	-	-	-	-	-
08/01/2026	-	-	-	-	-	-	-
02/01/2027	-	-	95,702.08	95,702.08	(95,702.08)	-	-
08/01/2027	-	-	57,421.25	57,421.25	-	57,421.25	-
02/01/2028	35,000.00	2.900%	57,421.25	92,421.25	-	92,421.25	149,842.50
08/01/2028	-	-	56,913.75	56,913.75	-	56,913.75	-
02/01/2029	75,000.00	2.850%	56,913.75	131,913.75	-	131,913.75	188,827.50
08/01/2029	-	-	55,845.00	55,845.00	-	55,845.00	-
02/01/2030	75,000.00	2.850%	55,845.00	130,845.00	-	130,845.00	186,690.00
08/01/2030	-	-	54,776.25	54,776.25	-	54,776.25	-
02/01/2031	80,000.00	2.900%	54,776.25	134,776.25	-	134,776.25	189,552.50
08/01/2031	-	-	53,616.25	53,616.25	-	53,616.25	-
02/01/2032	85,000.00	2.950%	53,616.25	138,616.25	-	138,616.25	192,232.50
08/01/2032	-	-	52,362.50	52,362.50	-	52,362.50	-
02/01/2033	250,000.00	3.050%	52,362.50	302,362.50	-	302,362.50	354,725.00
08/01/2033	-	-	48,550.00	48,550.00	-	48,550.00	-
02/01/2034	260,000.00	3.100%	48,550.00	308,550.00	-	308,550.00	357,100.00
08/01/2034	-	-	44,520.00	44,520.00	-	44,520.00	-
02/01/2035	270,000.00	3.200%	44,520.00	314,520.00	-	314,520.00	359,040.00
08/01/2035	-	-	40,200.00	40,200.00	-	40,200.00	-
02/01/2036	275,000.00	3.300%	40,200.00	315,200.00	-	315,200.00	355,400.00
08/01/2036	-	-	35,662.50	35,662.50	-	35,662.50	-
02/01/2037	285,000.00	3.450%	35,662.50	320,662.50	-	320,662.50	356,325.00
08/01/2037	-	-	30,746.25	30,746.25	-	30,746.25	-
02/01/2038	295,000.00	3.650%	30,746.25	325,746.25	-	325,746.25	356,492.50
08/01/2038	-	-	25,362.50	25,362.50	-	25,362.50	-
02/01/2039	305,000.00	3.800%	25,362.50	330,362.50	-	330,362.50	355,725.00
08/01/2039	-	-	19,567.50	19,567.50	-	19,567.50	-
02/01/2040	315,000.00	3.850%	19,567.50	334,567.50	-	334,567.50	354,135.00
08/01/2040	-	-	13,503.75	13,503.75	-	13,503.75	-
02/01/2041	330,000.00	3.950%	13,503.75	343,503.75	-	343,503.75	357,007.50
08/01/2041	-	-	6,986.25	6,986.25	-	6,986.25	-
02/01/2042	345,000.00	4.050%	6,986.25	351,986.25	-	351,986.25	358,972.50
Total	\$3,280,000.00	-	\$1,287,769.58	\$4,567,769.58	(95,702.08)	\$4,472,067.50	-

Significant Dates

Dated	4/01/2026
First Coupon Date	2/01/2027

Yield Statistics

Bond Year Dollars	\$35,488.33
Average Life	10.820 Years
Average Coupon	3.6287125%
Net Interest Cost (NIC)	3.7396222%
True Interest Cost (TIC)	3.7458796%
Bond Yield for Arbitrage Purposes	3.6081661%
All Inclusive Cost (AIC)	3.9889382%

IRS Form 8038

Net Interest Cost	3.6287125%
Weighted Average Maturity	10.820 Years

Series 2026A GO Equip Cer | SINGLE PURPOSE | 1/28/2026 | 10:07 AM



City of North Branch, Minnesota

\$3,280,000 General Obligation Equipment Certificates, Series 2026A

Assumes Current Market BQ AA Rates plus 50bps

Debt Service Schedule

Date	Principal	Coupon	Interest	Total P+I	CIF	Net New D/S	105% of Total
02/01/2027	-	-	95,702.08	95,702.08	(95,702.08)	-	-
02/01/2028	35,000.00	2.900%	114,842.50	149,842.50	-	149,842.50	157,334.63
02/01/2029	75,000.00	2.850%	113,827.50	188,827.50	-	188,827.50	198,268.88
02/01/2030	75,000.00	2.850%	111,690.00	186,690.00	-	186,690.00	196,024.50
02/01/2031	80,000.00	2.900%	109,552.50	189,552.50	-	189,552.50	199,030.13
02/01/2032	85,000.00	2.950%	107,232.50	192,232.50	-	192,232.50	201,844.13
02/01/2033	250,000.00	3.050%	104,725.00	354,725.00	-	354,725.00	372,461.25
02/01/2034	260,000.00	3.100%	97,100.00	357,100.00	-	357,100.00	374,955.00
02/01/2035	270,000.00	3.200%	89,040.00	359,040.00	-	359,040.00	376,992.00
02/01/2036	275,000.00	3.300%	80,400.00	355,400.00	-	355,400.00	373,170.00
02/01/2037	285,000.00	3.450%	71,325.00	356,325.00	-	356,325.00	374,141.25
02/01/2038	295,000.00	3.650%	61,492.50	356,492.50	-	356,492.50	374,317.13
02/01/2039	305,000.00	3.800%	50,725.00	355,725.00	-	355,725.00	373,511.25
02/01/2040	315,000.00	3.850%	39,135.00	354,135.00	-	354,135.00	371,841.75
02/01/2041	330,000.00	3.950%	27,007.50	357,007.50	-	357,007.50	374,857.88
02/01/2042	345,000.00	4.050%	13,972.50	358,972.50	-	358,972.50	376,921.13
Total	\$3,280,000.00	-	\$1,287,769.58	\$4,567,769.58	(95,702.08)	\$4,472,067.50	\$4,695,670.88

Significant Dates

Dated	4/01/2026
First Coupon Date	2/01/2027

Yield Statistics

Bond Year Dollars	\$35,488.33
Average Life	10.820 Years
Average Coupon	3.6287125%
Net Interest Cost (NIC)	3.7396222%
True Interest Cost (TIC)	3.7458796%
Bond Yield for Arbitrage Purposes	3.6081661%
All Inclusive Cost (AIC)	3.9889382%

City of North Branch, Minnesota

\$3,280,000 General Obligation Equipment Certificates, Series 2026A

Assumes Current Market BQ AA Rates plus 50bps

Debt Service Schedule

Date	Principal	Coupon	Interest	Total P+I	CIF	Existing D/S	Net New D/S	105% of Total
02/01/2027	-	-	95,702.08	95,702.08	(95,702.08)	205,200.00	205,200.00	215,460.00
02/01/2028	35,000.00	2.900%	114,842.50	149,842.50	-	206,500.00	356,342.50	374,159.63
02/01/2029	75,000.00	2.850%	113,827.50	188,827.50	-	167,700.00	356,527.50	374,353.88
02/01/2030	75,000.00	2.850%	111,690.00	186,690.00	-	169,600.00	356,290.00	374,104.50
02/01/2031	80,000.00	2.900%	109,552.50	189,552.50	-	166,400.00	355,952.50	373,750.13
02/01/2032	85,000.00	2.950%	107,232.50	192,232.50	-	163,200.00	355,432.50	373,204.13
02/01/2033	250,000.00	3.050%	104,725.00	354,725.00	-	-	354,725.00	372,461.25
02/01/2034	260,000.00	3.100%	97,100.00	357,100.00	-	-	357,100.00	374,955.00
02/01/2035	270,000.00	3.200%	89,040.00	359,040.00	-	-	359,040.00	376,992.00
02/01/2036	275,000.00	3.300%	80,400.00	355,400.00	-	-	355,400.00	373,170.00
02/01/2037	285,000.00	3.450%	71,325.00	356,325.00	-	-	356,325.00	374,141.25
02/01/2038	295,000.00	3.650%	61,492.50	356,492.50	-	-	356,492.50	374,317.13
02/01/2039	305,000.00	3.800%	50,725.00	355,725.00	-	-	355,725.00	373,511.25
02/01/2040	315,000.00	3.850%	39,135.00	354,135.00	-	-	354,135.00	371,841.75
02/01/2041	330,000.00	3.950%	27,007.50	357,007.50	-	-	357,007.50	374,857.88
02/01/2042	345,000.00	4.050%	13,972.50	358,972.50	-	-	358,972.50	376,921.13
Total	\$3,280,000.00	-	\$1,287,769.58	\$4,567,769.58	(95,702.08)	\$1,078,600.00	\$5,550,667.50	\$5,828,200.88

Significant Dates

Dated	4/01/2026
First Coupon Date	2/01/2027

Yield Statistics

Bond Year Dollars	\$35,488.33
Average Life	10.820 Years
Average Coupon	3.6287125%
Net Interest Cost (NIC)	3.7396222%
True Interest Cost (TIC)	3.7458796%
Bond Yield for Arbitrage Purposes	3.6081661%
All Inclusive Cost (AIC)	3.9889382%



Prepared By: Sharon Wright, Finance Director

Presenter: Sharon Wright, Finance Director

Date: 02/04/2026

Board & Commission: City Council

Subject: Approval to utilize interfund loans for purchase of equipment

City staff are seeking City Council's consent to proceed with interfund loans to fund the replacement of obsolete equipment. By using interfund loans rather than external financing, the City will pay interest to the originating fund (Generation). The interest paid by the borrowing funds will offset the interest that would otherwise have been earned on the invested money.

The equipment proposed for replacement includes a one-half-ton four-wheel-drive pickup and a three-quarter-ton cargo van for the General Fund Public Works Department; a three-quarter-ton pickup for the Sewer Fund; and a one-ton truck and a mini-excavator for the Water Fund.

These items all have a life expectancy of 10-15 years. The obsolete items will be auctioned off after they are replaced and any money will be placed in a designated fund for purchase of future equipment needs.

Voting Requirements:

Voting Options Simple Majority

CITY OF NORTH BRANCH, MN
INTERFUND LOAN AGREEMENT

Between Water Fund and Generation Fund

This Loan Agreement (“**Agreement**”) is executed as of February 11, 2026 between the City of North Branch, MN Water Fund (“**Borrower**”) and the City of North Branch, MN Generation Fund (“**Lender**”). Lender agrees to lend to Borrower, and Borrower agrees to repay to Lender an amount not to exceed the Principal Amount and interest accrued on the unpaid loan balance, in accordance with the following:

1. **Purpose of the Loan:** To provide funds for use by Borrower to fund equipment acquisition. The loan shall account for borrowing between the Water Fund (615) and the Generation Fund (620), and shall not be available for appropriation by the Lender or be considered revenue to the Lender or Borrower.
2. **Principal Loan Amount:** Not to exceed \$320,000 . The loan will be recorded as an interfund receivable by the Lender and an interfund payable by the Borrower.
3. **Term of the Loan:** The term of this loan shall begin on the date of execution and the outstanding loan balance is to be repaid by 12/31/2031.
4. **Scheduled Payments:** Borrower shall make payments no less than annually. Such payments are due thirty (30) days prior to the fiscal year end. At a minimum, annual Scheduled Payments shall equal the amount of any accrued interest through December 31st of that fiscal year. The loan may be prepaid, or paid prior to the end of the term, in part or whole without penalty. See Exhibit A – Repayment Schedule.
5. **Repayment Source:** Borrower must maintain a positive cash position to repay the loan; excess cash balance may be used to make additional payments. Missed scheduled payments shall be reported by the Finance Department to the City Administrator.
6. **Rate of Interest:** Interest shall accrue annually December 31 on the outstanding loan balance at the variable rates based on the City’s investment bearing accounts from which the money is being drawn, currently at 4.0% for the 2025 fiscal year. Loan interest will be recorded as revenue to the Lender and expenditures to the Borrower.
7. **General Provisions:** This Agreement constitutes the full Agreement by and between the Borrowing Fund and the Lending Fund and no other representations have been made regarding the contents of this Agreement. This Agreement shall not be amended, modified, or altered in any respect unless such amendment, modification, or alteration has been reduced to writing and executed by both parties.

LENDER:

City of North Branch, MN

Water Fund (615)

Signature of Director

Signature of City Administrator

BORROWER:

City of North Branch, MN

Generation Fund (620)

Signature of Director

Date

Exhibit A
Repayment Schedule
Water & Generation Interfund Loan

4.0% Interest Rate

Loan Amount \$ 320,000 \$71,880.68 Annual Pmt

Date of Pmt	Principal	Interest	Prin & Int	Balance
12/31/2027	59,080.68	12,800.00	71,880.68	\$260,919.32
12/31/2028	61,443.90	10,436.77	71,880.68	\$199,475.42
12/31/2029	63,901.66	7,979.02	71,880.68	\$135,573.76
12/31/2030	66,457.73	5,422.95	71,880.68	\$69,116.03
12/31/2031	69,116.03	2,764.64	71,880.68	\$0.00
	<u>\$ 320,000.00</u>	<u>\$ 39,403.38</u>	<u>\$ 359,403.38</u>	

CITY OF NORTH BRANCH, MN

INTERFUND LOAN AGREEMENT

Between Sewer Fund and Generation Fund

This Loan Agreement (“**Agreement**”) is executed as of February 11, 2026 between the City of North Branch, MN Sewer Fund (“**Borrower**”) and the City of North Branch, MN Generation Fund (“**Lender**”). Lender agrees to lend to Borrower, and Borrower agrees to repay to Lender an amount not to exceed the Principal Amount and interest accrued on the unpaid loan balance, in accordance with the following:

1. **Purpose of the Loan:** To provide funds for use by Borrower to fund equipment acquisition. The loan shall account for borrowing between the Sewer Fund (602) and the Generation Fund (620), and shall not be available for appropriation by the Lender or be considered revenue to the Lender or Borrower.
2. **Principal Loan Amount:** Not to exceed \$100,000 . The loan will be recorded as an interfund receivable by the Lender and an interfund payable by the Borrower.
3. **Term of the Loan:** The term of this loan shall begin on the date of execution and the outstanding loan balance is to be repaid by 12/31/2031.
4. **Scheduled Payments:** Borrower shall make payments no less than annually. Such payments are due thirty (30) days prior to the fiscal year end. At a minimum, annual Scheduled Payments shall equal the amount of any accrued interest through December 31st of that fiscal year. The loan may be prepaid, or paid prior to the end of the term, in part or whole without penalty. See Exhibit A – Repayment Schedule.
5. **Repayment Source:** Borrower must maintain a positive cash position to repay the loan; excess cash balance may be used to make additional payments. Missed scheduled payments shall be reported by the Finance Department to the City Administrator.
6. **Rate of Interest:** Interest shall accrue annually December 31 on the outstanding loan balance at the variable rates based on the City’s investment bearing accounts from which the money is being drawn, currently at 4.0% for the 2025 fiscal year. Loan interest will be recorded as revenue to the Lender and expenditures to the Borrower.
7. **General Provisions:** This Agreement constitutes the full Agreement by and between the Borrowing Fund and the Lending Fund and no other representations have been made regarding the contents of this Agreement. This Agreement shall not be amended, modified, or altered in any respect unless such amendment, modification, or alteration has been reduced to writing and executed by both parties.

LENDER:

City of North Branch, MN

Sewer Fund (602)

Signature of Director

Signature of City Administrator

BORROWER:

City of North Branch, MN

Generation Fund (620)

Signature of Director

Date

Exhibit A
Repayment Schedule
Sewer & Generation Interfund Loan

4.0% Interest Rate

Loan Amount \$ 100,000 \$22,462.71 Annual Pmt

Date of Pmt	Principal	Interest	Prin & Int	Balance
12/31/2027	18,462.71	4,000.00	22,462.71	\$81,537.29
12/31/2028	19,201.22	3,261.49	22,462.71	\$62,336.07
12/31/2029	19,969.27	2,493.44	22,462.71	\$42,366.80
12/31/2030	20,768.04	1,694.67	22,462.71	\$21,598.76
12/31/2031	21,598.76	863.95	22,462.71	\$0.00
	<u>\$ 100,000.00</u>	<u>\$ 12,313.56</u>	<u>\$ 112,313.56</u>	

CITY OF NORTH BRANCH, MN
INTERFUND LOAN AGREEMENT

Between General Fund and Generation Fund

This Loan Agreement (“**Agreement**”) is executed as of February 11, 2026 between the City of North Branch, MN General Fund (“**Borrower**”) and the City of North Branch, MN Generation Fund (“**Lender**”). Lender agrees to lend to Borrower, and Borrower agrees to repay to Lender an amount not to exceed the Principal Amount and interest accrued on the unpaid loan balance, in accordance with the following:

1. **Purpose of the Loan:** To provide funds for use by Borrower to fund equipment acquisition. The loan shall account for borrowing between the General Fund (101) and the Generation Fund (620), and shall not be available for appropriation by the Lender or be considered revenue to the Lender or Borrower.
2. **Principal Loan Amount:** Not to exceed \$120,000 . The loan will be recorded as an interfund receivable by the Lender and an interfund payable by the Borrower.
3. **Term of the Loan:** The term of this loan shall begin on the date of execution and the outstanding loan balance is to be repaid by 12/31/2031.
4. **Scheduled Payments:** Borrower shall make payments no less than annually. Such payments are due thirty (30) days prior to the fiscal year end. At a minimum, annual Scheduled Payments shall equal the amount of any accrued interest through December 31st of that fiscal year. The loan may be prepaid, or paid prior to the end of the term, in part or whole without penalty. See Exhibit A – Repayment Schedule.
5. **Repayment Source:** Borrower must maintain a positive cash position to repay the loan; excess cash balance may be used to make additional payments. Missed scheduled payments shall be reported by the Finance Department to the City Administrator.
6. **Rate of Interest:** Interest shall accrue annually December 31 on the outstanding loan balance at the variable rates based on the City’s investment bearing accounts from which the money is being drawn, currently at 4.0% for the 2025 fiscal year. Loan interest will be recorded as revenue to the Lender and expenditures to the Borrower.
7. **General Provisions:** This Agreement constitutes the full Agreement by and between the Borrowing Fund and the Lending Fund and no other representations have been made regarding the contents of this Agreement. This Agreement shall not be amended, modified, or altered in any respect unless such amendment, modification, or alteration has been reduced to writing and executed by both parties.

LENDER:

City of North Branch, MN

General Fund (101) Public Works

Signature of Director

Signature of City Administrator

BORROWER:

City of North Branch, MN

Generation Fund (620)

Signature of Director

Date

Exhibit A
Repayment Schedule
General & Generation Interfund Loan

4.0% Interest Rate

Loan Amount \$ 120,000 \$26,955.25 Annual Pmt

Date of Pmt	Principal	Interest	Prin & Int	Balance
12/31/2027	22,155.25	4,800.00	26,955.25	\$97,844.75
12/31/2028	23,041.46	3,913.79	26,955.25	\$74,803.28
12/31/2029	23,963.12	2,992.13	26,955.25	\$50,840.16
12/31/2030	24,921.65	2,033.61	26,955.25	\$25,918.51
12/31/2031	25,918.51	1,036.74	26,955.25	\$0.00
	<u>\$ 120,000.00</u>	<u>\$ 14,776.27</u>	<u>\$ 134,776.27</u>	

MEMORANDUM

To: The Honorable Kevin Schieber
City of North Branch City Council **VIA EMAIL ONLY**

cc: Matthew Hill, City Administrator

From: Christopher M. Hood

Date: February 4, 2026

Re: Legal Staff Report for February 10, 2026 City Council Meeting

We are submitting this memorandum to update the City of North Branch City Council on the work we performed as City Attorney during January 2026. The matters listed below are discussed in a general manner only for sake of brevity and to maintain any attorney-client privileged and/or confidential information/data.

Summary of City Matters

1. **Personnel and Labor Matters**
Attorneys reviewed, analyzed, and responded to questions regarding personnel matters and a data request.
2. **Municipal Matters**
Attorneys researched, reviewed, analyzed, advised and drafted a memorandum to Council on a septic system matter. Attorneys researched, reviewed, analyzed, advised and drafted a gambling control ordinance.
3. **Land Use and Real Estate Matters**
Attorneys reviewed, advised and drafted an amendment to a purchase agreement. Attorneys reviewed and advised on closing of a real estate transaction.
4. **Staff Communications**
Attorneys also make occasional day-to-day communications with the City Administrator, City Engineer and City staff regarding the above-referenced matters, among others.

CMH/sc



Prepared By: Matthew Hill, City Administrator

Presenter: Matthew Hill, City Administrator

Date: 01/19/2026

Board & Commission: City Council

Subject: Consider approval of Ordinance 407-26 allowing the procurement of charitable gambling proceeds for park and trail additions and maintenance funding.

Background:

The City has been investigating revenue opportunities to enhance public service while being budget neutral for the residents. One opportunity that has been implemented in many communities throughout the State is utilizing the ability of collecting 10% of the charitable gambling net income derived from local pull tabs. The City is proposing an ordinance that can ensure the long-term sustainability and enhancement of our city's public green spaces and recreational infrastructure. It establishes a necessary and dedicated funding mechanism by collecting 10% of the charitable gambling net income derived from local pull tabs.

This new revenue stream would be specifically earmarked to fund the following:

- **Additions and Expansion:** New development and expansion of parks and trails within the city.
- **Maintenance:** Essential ongoing maintenance and necessary repairs to our existing parks and trails network.

Ordinance 407-26 provides a stable, local funding solution that directly links a community-generated revenue source to a highly valued community asset. By dedicating a portion of charitable gambling income, the City Council can ensure that our parks and trails remain accessible, well-maintained, and continuously improved for the benefit of all residents.

Ordinance 407-26 has been reviewed by the City Attorney's office.

Action Requested:

Motion and Second to approve Ordinance 407-26 allowing the procurement of charitable gambling proceeds for park and trail additions and maintenance funding.

Voting Requirements:

Voting Options Simple Majority

CITY OF NORTH BRANCH

ORDINANCE NO. 407-26

AN ORDINANCE OF THE CITY OF NORTH BRANCH, MINNESOTA, PERTAINING TO THE PROCUREMENT OF CHARITABLE GAMBLING PROCEEDS FOR PARK AND TRAIL ADDITIONS AND MAINTENANCE FUNDING.

WHEREAS, the City of North Branch is authorized to promote the general welfare, public safety, and public good of its residents; and

WHEREAS, the maintenance and improvement of public parks and trails are essential for the quality of life of the residents of North Branch; and

WHEREAS, local charitable gambling organizations operating within the City of North Branch contribute to the community, and the City desires a mechanism to support public infrastructure through a portion of these proceeds;

NOW, THEREFORE, THE CITY COUNCIL OF THE CITY OF NORTH BRANCH ORDAINS:

Section 1. Purpose, Intent and Authorization

The purpose of this Ordinance is to establish a legal framework for the City of North Branch to procure a dedicated percentage of the net gambling proceeds from charitable gambling organizations operating within the city limits, for the sole purpose of funding the maintenance, repair, additions and improvement of City-owned parks and trails. The City Council is authorized by the provisions of Minn. Stat. § 349.213, as it may be amended from time to time, to impose additional restrictions on gambling within its limits, including the collection of a portion of net profits derived from lawful gambling.

Section 2. Definitions.

- Charitable Gambling Organization: Any organization licensed by the State of Minnesota pursuant to Minn. Stat. § 349.16, as it may be amended from time to time, to conduct lawful gambling activities within the City of North Branch and as further authorized under North Branch City Code.
- Net Gambling Proceeds: The gross receipts of lawful gambling minus prizes actually paid, allowable expenses, and taxes imposed by law.
- City: The City of North Branch, Minnesota.

Section 3. Procurement of Proceeds.

- A. Every Charitable Gambling Organization operating within the City of North Branch shall remit ten percent (10%) of its Net Gambling Proceeds to the City.
- B. The remittance required by this section shall be made quarterly and shall be accompanied by a report detailing the calculation of the Net Gambling Proceeds for the period, and such report shall be in a form acceptable to the City in order to ensure compliance with the City's reporting requirements under Minn. Stat. 349.213, as may be amended from time to time.
- C. The City Council is authorized to establish, by resolution, rules and procedures for the collection, reporting, and auditing of these proceeds to ensure compliance with this Ordinance and state law.

Section 4. Establishment of the Park and Trail Improvement and Maintenance Fund.

- A. All funds procured by the City under Section 3 of this Ordinance shall be deposited into a dedicated, segregated fund to be known as the Park and Trail Improvement and Maintenance Fund.
- B. The monies in the Park and Trail Improvement and Maintenance Fund shall be used exclusively for the ongoing maintenance, repair, capital improvements, and development of public parks and trails owned or operated by the City of North Branch, and the use of such funds shall be determined at the time of adoption of the City's annual budget or whenever said budget is amended.
- C. All expenditures authorized under this Ordinance shall be reported by City staff to the designated state agency annually pursuant to Minn. Stat. 349.213 subd.1(f)(2), as may be amended from time to time.

Section 5. Conflict and Severability.

- A. All ordinances or parts of ordinances in conflict herewith are hereby repealed.
- B. If any section, subsection, sentence, clause, phrase, or portion of this Ordinance is for any reason held invalid or unconstitutional by any court of competent jurisdiction, such portion shall be deemed a separate, distinct, and independent provision, and such holding shall not affect the validity of the remaining portions of this Ordinance.
- C. This Ordinance shall supplement existing regulations on the operation of Charitable Gambling Organizations as reflected in the North Branch City Code, chapter 18, article 4, as may be amended from time to time.

Section 6. Enforcement.

Failure of a Charitable Gambling Organization to comply with the requirements of this Ordinance shall be deemed violation of City Code, and shall subject to enforcement action under City Code Section 18-97, as may be amended from time to time, including the potential suspension or revocation of any operating license.

Section 7. Effective Date.

This Ordinance shall take effect upon its passage and publication as required by law.

PASSED AND ADOPTED by the City Council of the City of North Branch, Minnesota,
this _____ day of _____, 2026.

APPROVED: _____
Mayor

ATTEST: _____
City Clerk